



INSTRUMENTS

Beacon 410 Gas Monitor Operator's Manual

Part Number: 71-0131RK

Revision: D

Released: 10/16/12

Product Warranty

RKI Instruments, Inc., warrants gas alarm equipment sold by us to be free from defects in materials, workmanship, and performance for a period of one year from date of shipment from RKI Instruments, Inc. Any parts found defective within that period will be repaired or replaced, at our option, free of charge. This warranty does not apply to those items, which by their nature, are subject to deterioration or consumption in normal service, and which must be cleaned, repaired, or replaced on a routine basis. Examples of such items are as follows:

- a) Absorbent cartridges
- b) Pump diaphragms and valves
- c) Fuses
- d) Batteries
- e) Filter elements

Warranty is voided by abuse including mechanical damage, alteration, rough handling, or repair procedures not in accordance with the operator's manual. This warranty indicates the full extent of our liability, and we are not responsible for removal or replacement costs, local repair costs, transportation costs, or contingent expenses incurred without our prior approval.

THIS WARRANTY IS EXPRESSLY IN LIEU OF ANY AND ALL OTHER WARRANTIES AND REPRESENTATIONS, EXPRESSED OR IMPLIED, AND ALL OTHER OBLIGATIONS OR LIABILITIES ON THE PART OF RKI INSTRUMENTS, INC., INCLUDING BUT NOT LIMITED TO, THE WARRANTY OF MERCHANTABILITY OR FITNESS FOR A PARTICULAR PURPOSE. IN NO EVENT SHALL RKI INSTRUMENTS, INC., BE LIABLE FOR INDIRECT, INCIDENTAL, OR CONSEQUENTIAL LOSS OR DAMAGE OF ANY KIND CONNECTED WITH THE USE OF ITS PRODUCTS OR FAILURE OF ITS PRODUCTS TO FUNCTION OR OPERATE PROPERLY.

This warranty covers instruments and parts sold to users by authorized distributors, dealers, and representatives as appointed by RKI Instruments, Inc.

We do not assume indemnification for any accident or damage caused by the operation of this gas monitor, and our warranty is limited to the replacement of parts or our complete goods.

Table of Contents

Chapter 1: Introduction	1
Overview	1
About the Beacon 410 Gas Monitor	1
About this Manual	1
Specifications	3
Chapter 2: Description	4
Overview	4
External Description	4
Internal Description	5
Optional Accessories	11
Chapter 3: Installation and Start Up	14
Overview	14
Mounting the Beacon 410 Gas Monitor	14
Wiring the Beacon 410 Gas Monitor	15
Starting Up the Beacon 410 Gas Monitor	22
Chapter 4: Operation	24
Overview	24
Normal Operation	24
4 - 20 mA Signal Output Operation	24
Viewing and Resetting Min/Max Readings	25
Battery Charging (Optional)	25
Alarm Indications	26
Chapter 5: Global Menu	32
Overview	32
Viewing and Changing Global Parameters	32
Chapter 6: Configuration Menu	35
Overview	35
Viewing and Changing Channel Parameters	35
Chapter 7: Input Setup Menu	41
Overview	41
Selecting the Detector Head Input Type and Gas Setup	41

Chapter 8: Calibration Mode	45
Overview	45
Calibration Frequency	45
Detector Head Types	46
Calibration Gas Response Memory Feature	46
Entering Calibration Mode	47
Calibration Timeout Setting	47
Performing a Calibration	48
Viewing Maximum Spans	52
Chapter 9: RS-485 Modbus Output	54
Overview	54
Wiring the Beacon 410 in a Modbus System	54
Using the Beacon 410 in a 4-wire Modbus System	56
Modbus Menu	56
Supported Modbus Functions	58
Chapter 10: Maintenance	64
Overview	64
Preventive Maintenance	64
Troubleshooting	64
Replacing the AC Fuses	66
Parts List	66

Chapter 1: Introduction

Overview

This chapter briefly describes the Beacon 410 Gas Monitor. This chapter also describes the *Beacon 410 Gas Monitor Operator's Manual* (this document). Table 1 at the end of this chapter lists the specifications for the Beacon 410.

About the Beacon 410 Gas Monitor

The Beacon 410 is a fixed-mounted, continuous-monitoring controller. This multiple channel gas monitor is capable of detecting gas at up to four locations. The display screen simultaneously displays the gas readings of all active channels. Both direct connect (internal amplifier type) detector heads and 4 - 20 mA transmitter (remote amplifier type) detector heads may be used with the Beacon 410.

The Beacon 410 includes audible and visual alarms that warn you of hazardous gas conditions. The alarm circuits include up to three levels of gas alarms. The fail circuit alerts you to failures in the detector heads or Beacon 410.

The Beacon 410 has four selection menus that allow you to configure various Beacon 410 channel and instrument parameters, the Global Menu, Configuration Menu, Input Setup Menu, and Modbus Menu. It also has an operational mode, Calibration Mode, that enables you to calibrate the Beacon 410's active channels.

About this Manual

The *Beacon 410 Gas Monitor Operator's Manual* is organized as follows:

- **Chapter 1** is an introduction to the Beacon 410.
- **Chapter 2** describes the components of the Beacon 410.
- **Chapter 3** describes the installation and start-up procedures of the Beacon 410.
- **Chapter 4** describes the operation of the Beacon 410.
- **Chapter 5** describes the Global Menu which allows you to set instrument parameters.
- **Chapter 6** describes the Configuration Menu which allows you to set channel parameters.
- **Chapter 7** describes the Input Setup Menu which allows you to set the input type for each channel.
- **Chapter 8** describes Calibration Mode which allows you to calibrate the Beacon 410's active channels.
- **Chapter 9** describes the Beacon 410's RS-485 Modbus output.
- **Chapter 10** describes the Beacon 410's maintenance requirements and procedures.

The *Beacon 410 Gas Monitor Operator's Manual* uses the following conventions for notes, cautions, and warnings:

NOTE: Describes additional or critical information.

CAUTION: *Describes potential damage to equipment.*

WARNING: *Describes potential danger that can result in injury or death.*



Caution: refer to accompanying documentation



Vac (AC voltage)



Vdc (DC voltage)

Specifications

Table 1 lists specifications for the Beacon 410.

Table 1: Beacon 410 Specifications

Description	Specification
Input Power	100/115/220V ~ ±10%, 50/60Hz, 1.0/1.0/0.5A or 24 V $\overline{\text{---}}$ ± 10%, 2.5A VDC
Construction (housing)	Fiberglass/polyester with lexan window (NEMA 4X)
Dimensions	12.5 in. H x 11.0 in. W x 6.4 in. D (31.8 cm H x 27.9 cm W x 16.3 cm D)
Weight	10.4 lbs. (without AC line cord)
Environmental Conditions	<ul style="list-style-type: none"> • For indoor or outdoor locations (Type 4X) • 2000m max. altitude • -20°C to 50°C (-4°F to 122°F) max. ambient • Maximum humidity of 80% relative • Mains supply voltage fluctuations not exceeding ± 10% of nominal • DC supply voltage fluctuations not exceeding +10% -8% of nominal • Overvoltage Category II, Pollution Degree 2
Safety/Regulatory	 C US 186718
User Controls	<ul style="list-style-type: none"> • Reset switch • Program buttons: ESCAPE, UP/YES, DOWN /NO, and ENTER)
Relays	<ul style="list-style-type: none"> • Relay contacts rated for 10A @ 115/220V~ resistive or 10A @ 30V $\overline{\text{---}}$ resistive • SPDT, Form C (common, normally open, and normally closed contacts)
Standard Accessory	Operator's manual (this document)

Chapter 2: Description

Overview

This chapter describes the Beacon 410's external and internal components.

External Description

This section describes the housing and all external components of the Beacon 410. For the purposes of this description, the housing door is considered the front of the monitor.

Housing

The Beacon 410's fiberglass housing is weather- and corrosion-resistant. It is suitable for installation where general purpose equipment is in use. The housing door is hinged on the left side and is secured by two latches on the right side. The LCD display and status LEDs are visible through windows in the housing door. Four mounting feet are attached to the back of the housing (one at each corner). The mounting feet allow you to install the housing to a vertical surface. Four conduit hubs on the bottom of the housing are for external wiring connections.

CAUTION: *To avoid electrical interference, do not route detector head and power wiring through the same conduit hub.*

Reset Switch

The reset switch is on the bottom of the housing in front of the buzzer. The reset switch serves four functions:

- Resets the alarm circuits for "latched" alarms after an alarm 1, alarm 2, or alarm 3 condition passes.

You can set each channel for latched or self-resetting alarms in the Configuration Menu. See "Viewing and Changing Channel Parameters" on page 35 for more information.
- Silences the buzzer during an alarm 1, alarm 2, or alarm 3 condition if the buzzer silence parameter in the Global Menu is set to **CAN SILENCE BUZZER**. See "Viewing and Changing Global Parameters" on page 32 for more information on setting the silence feature.
- Resets the strobe during an alarm 1, alarm 2, or alarm 3 condition if the strobe alarm setting parameters are set to **Resettable STROBE** in the Configuration Menu. See "Viewing and Changing Channel Parameters" on page 35 for more information on setting the strobe alarm setting parameters.
- Displays and resets the minimum and maximum gas concentration values detected.

NOTE: Fail alarms cannot be reset or acknowledged with the reset switch. When a fail condition passes, the Beacon 410 will automatically reset the fail alarm circuit.

Buzzer

The buzzer is on the bottom of the housing, behind the reset switch. The buzzer sounds an audible alarm to warn you of gas alarms and instrument failures.

Internal Description

This section describes the internal components of the Beacon 410.

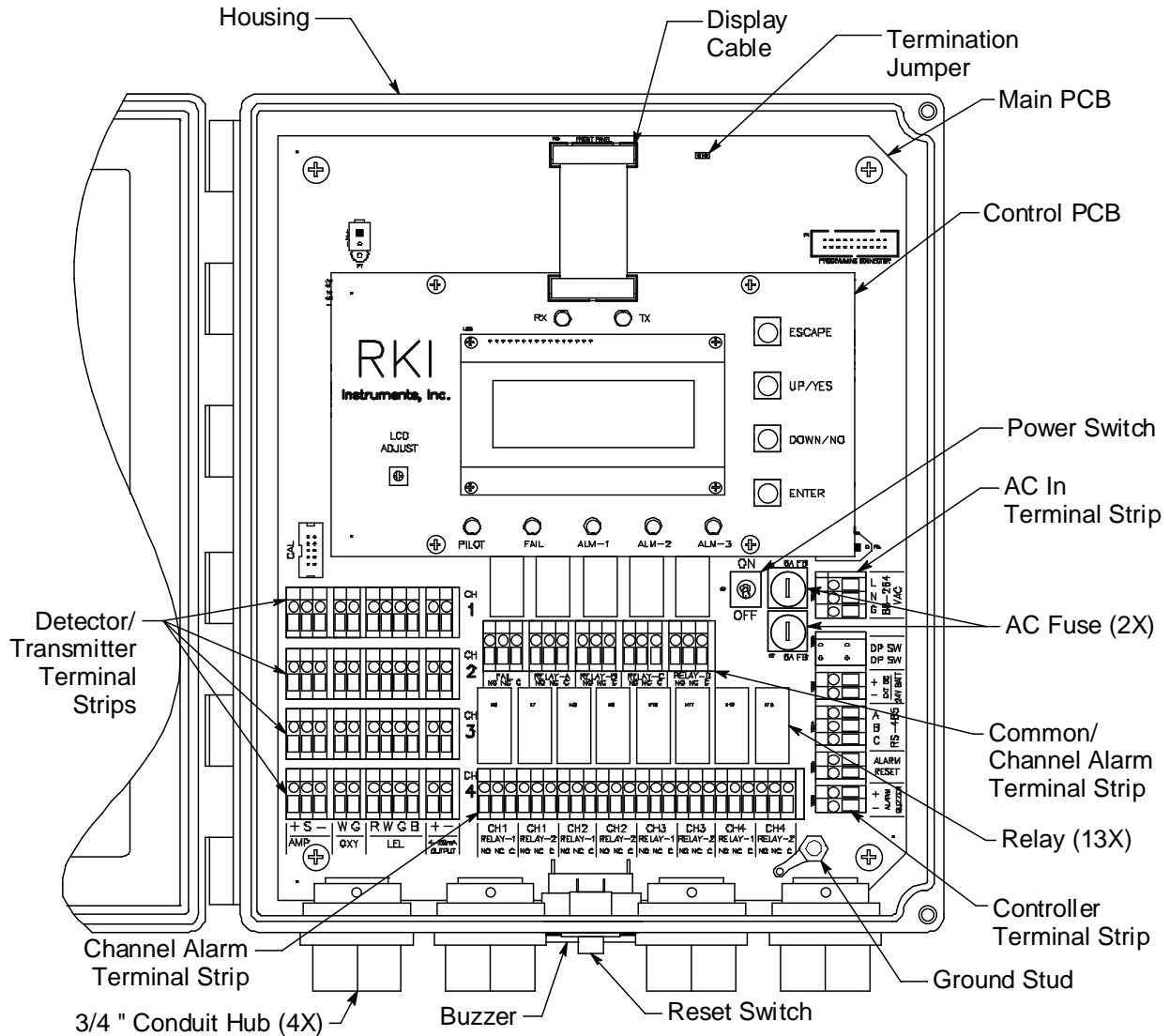

Figure 1: Beacon 410 Gas Monitor Component Location

Control PCB

The control PCB (printed circuit board) is mounted to the power supply mounting plate which is in turn mounted to the main PCB. The power supply mounting plate and main PCB are described below. The control PCB includes the LCD display, the LCD contrast adjust pot, the status LEDs, and the program buttons. It is connected to the main PCB by the display cable which is a 20 conductor ribbon cable assembly. The display cable connects to a rectangular connector on the top edge of the control PCB and to the same type of connector labelled "FRONT PANEL" on the top edge of the main PCB.

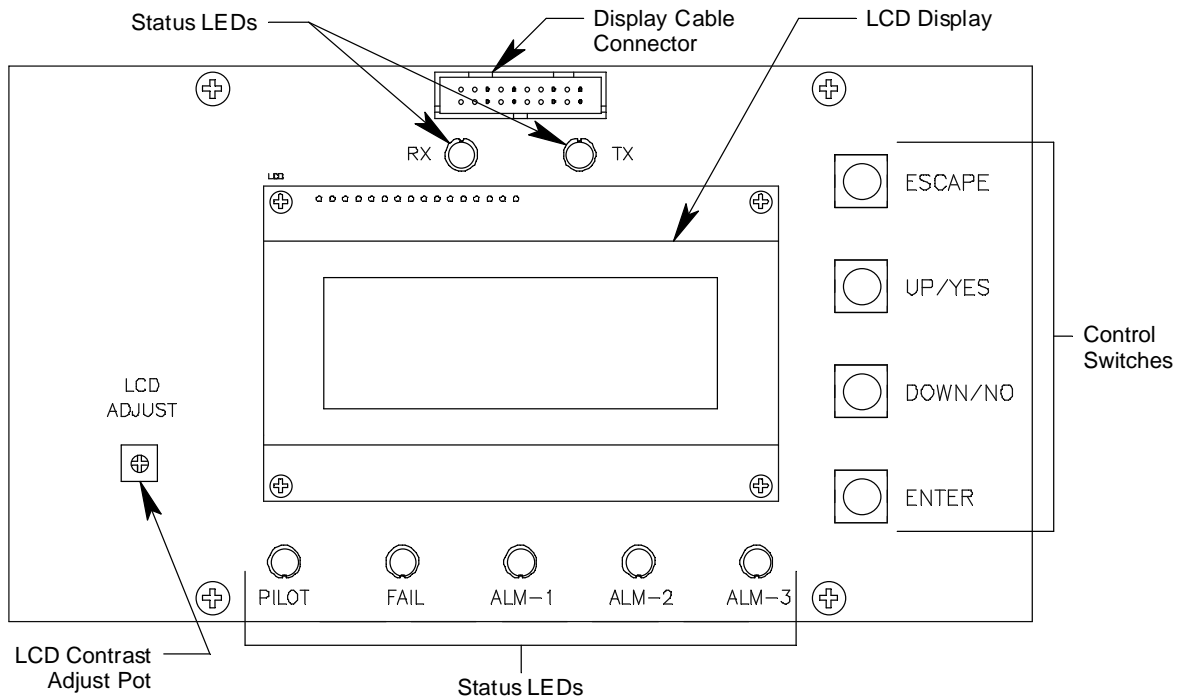

Figure 2: Control PCB Component Location

LCD Display

During normal operation, the four line display simultaneously indicates the target gas, current gas reading, and measuring unit of each active channel. The display also shows messages, settings, and other data when you are operating the various selection menus and operating modes.

LCD Contrast Adjust Pot

The LCD contrast adjust pot is located to the left of the LCD. If the LCD contrast is too dark or too light to read easily, use a small phillips screwdriver adjust it until you can easily read the LCD.

Status LEDs

The Beacon 410 includes seven status LEDs that indicate the current status of the monitor: the RX & TX LEDs, the pilot LED, the fail LED, the alarm 1 LED, the alarm 2 LED, and the alarm 3 LED (see Figure 2).

- **RX & TX LEDs**

These LEDs indicate data being received (RX) and transmitted (TX) when the Beacon 410's Modbus output is operating.

- **Pilot LED**

The PILOT LED is on when the Beacon 410 is receiving incoming power, either AC or DC power.

- **Fail LED**

The fail LED turns on when the Beacon 410 is experiencing a fail condition. A fail condition can be caused by a failure within the Beacon 410 or the detector heads

wired to the Beacon 410 (see “Chapter 10: Maintenance” on page 64).

- Alarm 1 LED
The alarm 1 LED is on when the Beacon 410 is experiencing an alarm 1 condition.
- ALARM 2 LED
The alarm 2 LED is on when the Beacon 410 is experiencing an alarm 2 condition.
- ALARM 3 LED
The alarm 3 LED is on when the Beacon 410 is experiencing an alarm 3 condition.

Control Buttons

The Beacon 410 includes four control buttons that allow you to enter the selection menus and Calibration Mode, navigate through the menus and Calibration Mode, update instrument and channel parameter settings, and save changes to the settings. The control buttons, listed in Table 2, are to the right of the LCD display (see Figure 2).

Table 2: Beacon 410 Control Button Functions

Button	Function
ESCAPE	<ul style="list-style-type: none">• Moves backward through the menu and mode screens• Aborts operations• Cancels changes you make in the menus• Enters the Configuration Menu (press with ENTER button)• Enters the Global Menu (press with the UP/YES button)
UP (YES)	<ul style="list-style-type: none">• Initiates an operation or proceeds to the next screen when a yes/no question is asked on a screen• Changes the displayed setting• Enters the Global Menu (press with ESCAPE) button• Enters the Calibration Mode (press with ENTER button)
DOWN (NO)	<ul style="list-style-type: none">• Cancels an operation or sequence when a yes/no question is asked on a screen.• Changes the displayed setting• Enters the Modbus Menu (press with ENTER button)
ENTER	<ul style="list-style-type: none">• Saves changes you make in the menu and mode screens• Accepts the displayed parameter setting• Enters the Configuration Menu (press with ESCAPE button)• Enters Calibration Mode (press with UP/YES button)• Enters the Modbus Menu (press with DOWN/NO button)

Main PCB

Terminal Strips

The Beacon 410 includes 9 terminal strips for wiring connections. See “Wiring the Beacon 410 Gas Monitor” on page 15 for detailed wiring procedures.

- Strobe Terminal Strip
The strobe terminal strip is a 2-point terminal strip located in the upper left corner of the main PCB. When the optional strobe is ordered with a Beacon 410, the strobe terminal strip is used to factory wire the strobe.

CAUTION: *The strobe terminals are intended for use with the RKI supplied optional strobe. Consult RKI Instruments, Inc. before attempting to use these terminals for some other alarm device.*

- **Detector/Transmitter Terminal Strips**
 Four detector/transmitter terminal strips are located along the bottom left side of the main PCB (see Figure 1 on page 5). These four 11-point terminal strips facilitate wiring connections to the detector heads. They also provide terminals to connect a recording device to a 4 to 20 mA output for each channel. The top terminal strip is for channel 1 connections and each subsequent strip is used for the next channel with the bottom terminal strip being for channel 4 connections.
- **Channel Alarm Terminal Strip**
 A channel alarm terminal strip is located to the right of the channel 4 detector/transmitter terminal strip (see Figure 1 on page 5). This 24-point terminal strip facilitates wiring external alarm devices (horn, light, etc.) to relay contacts that are field configurable for alarm levels and operation and are controlled by individual channels. The contacts are labelled NO (normally open), NC (normally closed), and C (common). See “Viewing and Changing Global Parameters” on page 32 and “Viewing and Changing Channel Parameters” on page 35 for instructions to configure the operation of these contacts.
- **Common/Channel Alarm Terminal Strip**
 The common/channel alarm terminal strip is located in approximately the middle of the main PCB above the channel alarm terminal strip. This 15-point terminal strip facilitates wiring external alarm devices (horn, strobe, etc.) to relay contacts that are field configurable as individual alarm contacts that are controlled by individual channels or as common alarm contacts which are controlled by all channels. The contacts are labelled NO (normally open), NC (normally closed), and C (common). See “Viewing and Changing Global Parameters” on page 32 and “Viewing and Changing Channel Parameters” on page 35 for instructions to configure the operation of these contacts.
- **Controller terminal strip**
 The 9-point controller terminal strip is along the lower right side of the main PCB (see Figure 1 on page 5). The controller terminal strip facilitates various internal and external wiring connections. Table 3 lists the function of each terminal.

Table 3: Terminal Assignments for the Controller Terminal Strip

Terminal	Connects to:
EXT DC/24V BATT +	+ connection from 24 VDC power source ¹ (or 24 V backup battery) ¹
EXT DC/24V BATT -	- connection from 24 VDC power source ¹ (or 24 V backup battery) ¹
RS-485 A	Allow connection of the Beacon 410 to a Modbus network
RS-485 B	
RS-485 C	

Table 3: Terminal Assignments for the Controller Terminal Strip (Continued)

Terminal	Connects to:
Alarm Reset	Reset Switch Terminals (factory wired)
Alarm Reset	
Alarm Buzzer +	Buzzer + connection (factory wired)
Alarm Buzzer -	Buzzer - connection (factory wired)
¹ If 24 VDC is used as primary power source do not make wiring connections to the AC terminal strip.	

- AC terminal strip

The 3-point AC terminal strip is located above the controller terminal strip (see Figure 1 on page 5). The AC terminal strip facilitates wiring connections to the AC power source.

Relays

The Beacon 410 includes eight channel relays and one common fail relay. It also includes four common/channel relays that can be defined as a group as channel or common relays. All the relays have single-pole double-throw (SPDT) contacts, also known as form C contacts, and are rated for 10 amps at 115 VAC (resistive). The contacts are available at the channel alarm and common/channel alarm terminal strips and are labelled NO (normally open), NC (normally closed), and C (common).

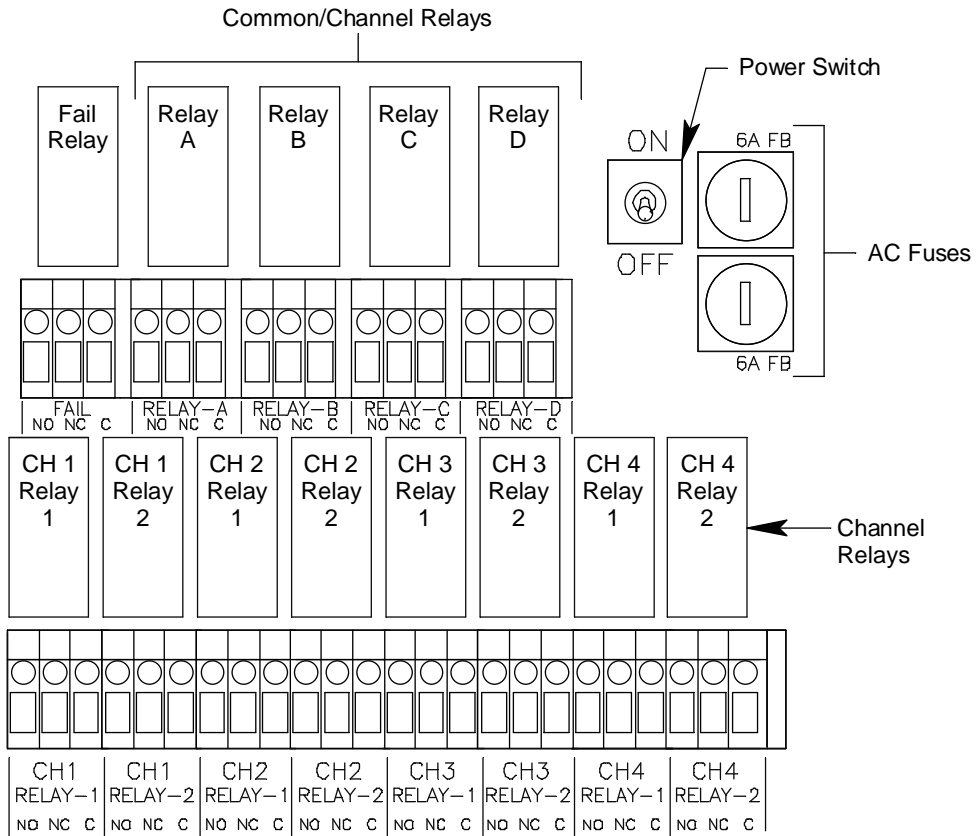

Figure 3: Beacon 410 Relay Allocation

Channel Relays & Fail Relay

The eight channel relays are above the channel alarm terminal strip (see Figure 1 on page 5 and Figure 3 on page 9). These relays are dedicated to specific channels. Figure 3 illustrates the allocation of the channel relays.

The fail relay is located directly to the left of the channel relays. The fail relay is a common relay.

Common/Channel Relays

The four common/channel relays are above the common/channel alarm terminal strip (see Figure 1 on page 5 and Figure 3 on page 9). These relays can be configured as either all channel relays or all common relays in the Global Menu.

Termination Jumper

A two pin header with a termination jumper installed is located near the top edge of the main PCB to the right of the display cable connector. It is labelled "RS-485 Line Terminator" on the PCB silkscreen. The jumper has no function unless the Beacon 410 is wired into a Modbus installation. See "Chapter 9: RS-485 Modbus Output" on page 54 for instructions to use the Beacon 410 in a Modbus system.

Ground Stud

The threaded ground stud is used for making connections to earth ground. It is located in the lower right corner of the Main PCB and is connected through the main PCB to the **G** (ground) terminal on the AC terminal strip. A kee nut on the stud may be removed for installation of one or more user supplied lugs to make wiring connections to earth ground. This stud is typically used to connect the shield drain wire of shielded cable to earth ground at the Beacon 410.

Power Switch

The power switch is between the common/channel relays and the fuses (see Figure 1 on page 5 and Figure 3 on page 9). The power switch turns the incoming AC power source on and off at the Beacon 410. When the switch is up, the power is on.

Power Supply

The power supply is mounted to the power supply mounting plate which is located behind the display PCB. The power supply mounting plate is mounted to the main PCB with four standoffs. The power supply receives AC power from the external power source and converts it to a DC voltage that is usable by the Beacon 410 circuitry. A polycarbonate cover prevents accidental contact with the AC terminals on the power supply.

AC & DC Circuit Protection

Two AC fuses are used in the Beacon 410. The two fuses are located on the right side of main PCB, between the power switch and the AC in terminal strip (see Figure 1 on page 5 and Figure 3 on page 9). They cut off the incoming AC power in the event of a short circuit or other electrical fault which causes a high current draw in the Beacon 410. They are housed in vertical fuse holders and are held in each holder by a quarter turn cover. They are fast blow fuses rated at 6 A, 250 V.

A polyswitch is used to protect the DC power input. It is located on the right side of the main PCB above the AC fuses and is labelled on the PCB silkscreen as PS9. In the event of a short circuit or other electrical fault which causes a high current draw in the Beacon 410, the polyswitch will interrupt the DC power if the unit is powered from DC. When the fault situation is corrected, the polyswitch resets and the unit will continue to operate. The polyswitch is not user serviceable.

Optional Accessories

This section describes the optional accessories available for the Beacon 410. Both optional accessories are wired to the Strobe Terminal Strip as shown below.

Strobe Terminal Strip

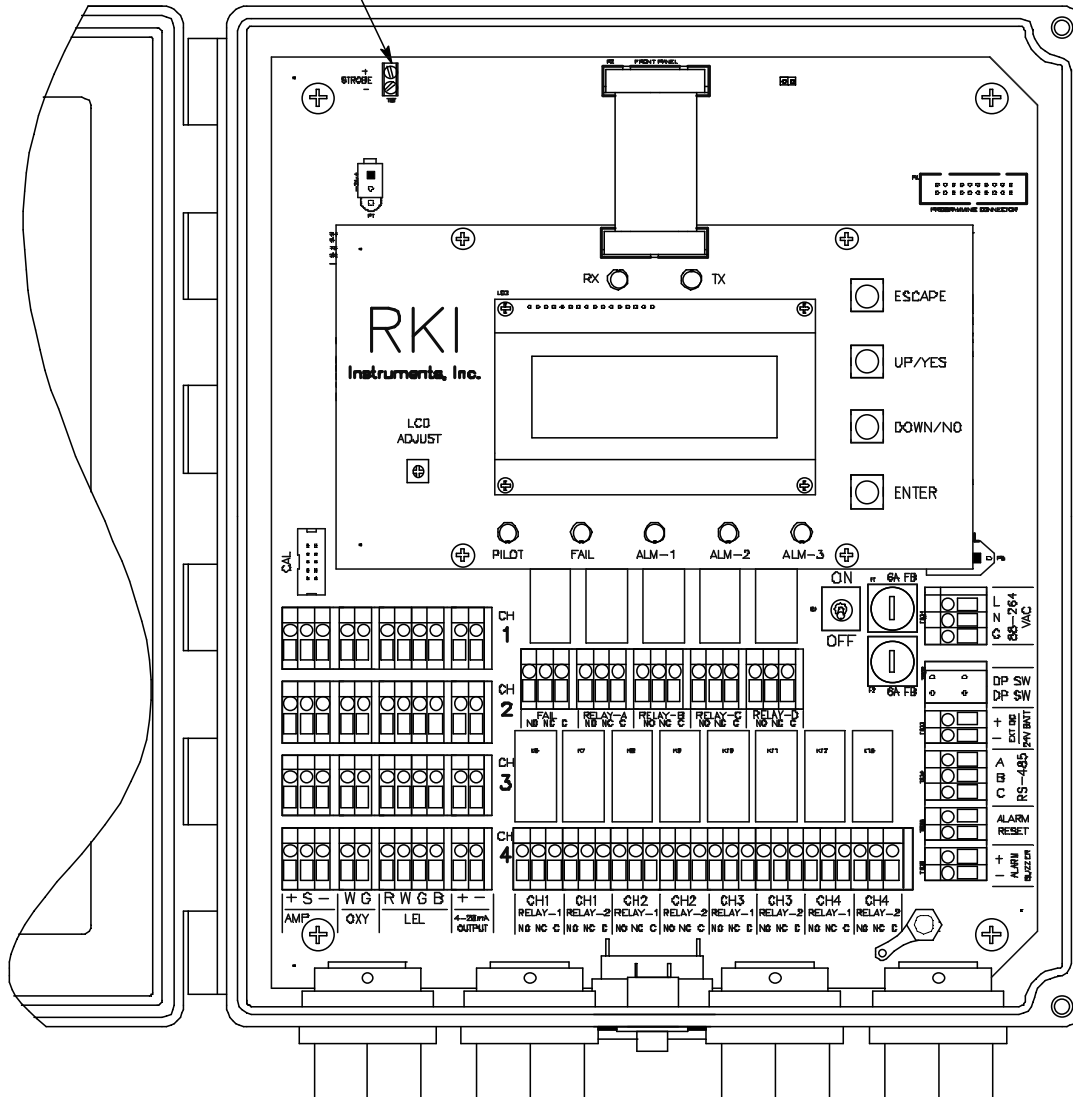

Figure 4: Strobe Terminal Strip Location

Alarm Strobe

The Beacon 410 can be ordered with a red alarm strobe light installed on the top of the housing. The Beacon 410 retains its NEMA 4X rating with the strobe installed. Strobe operation can be programmed in Configuration Mode (see “Chapter 6: Configuration Menu” on page 35). The outline and mounting dimensions with the alarm strobe are the same as the standard Beacon 410 with the exception of the height. The difference is shown below. See Figure 7 for all outline and mounting dimensions.

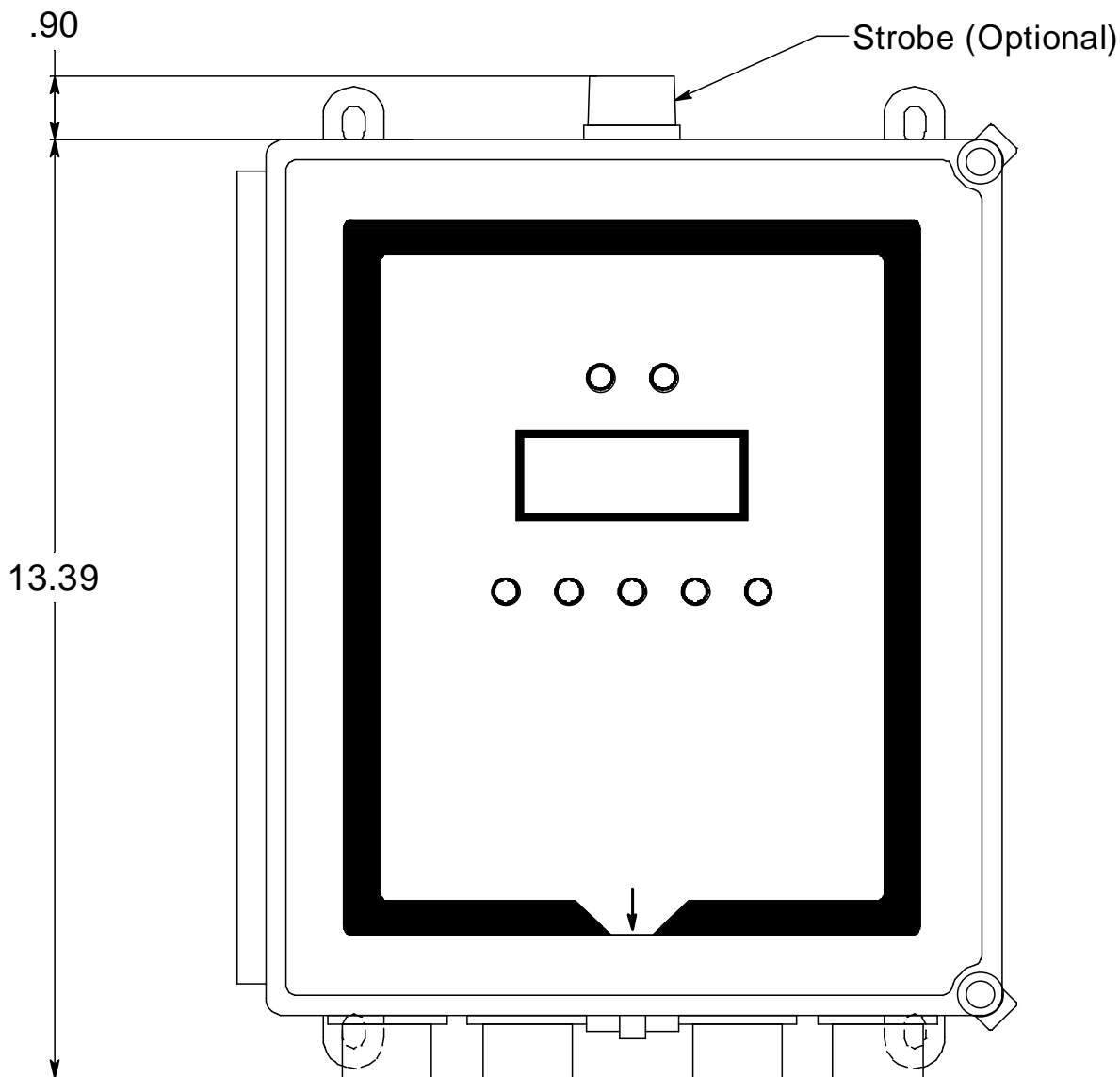

Figure 5: Alarm Strobe Dimensions

Horn/Strobe

The Beacon 410 can be ordered with a horn/strobe. This optional horn/strobe allows the user to have both a strobe and a horn connected to the “Strobe” terminals of the Beacon 410. It also allows the user to mount the horn/strobe away from the Beacon 410 so that it can be somewhere more visible/audible. Strobe operation can be programmed in Configuration Mode (see “Chapter 6: Configuration Menu” on page 35).

NOTE: See “Chapter 3: Installation and Start Up” on page 14 for complete Beacon 410 installation instructions.

CAUTION: Do not adjust the strobe brightness or the horn volume at the strobe/horn, as this may overload the Beacon 410 strobe control circuit.

The horn/strobe does not come factory installed to the Beacon 410. To install the horn/strobe:

1. Mount the horn/strobe in the desired location.
2. Install an appropriately rated cable bushing or conduit to the left conduit hub on the bottom of the Beacon 410 housing.
3. Install an appropriately rated cable bushing or conduit at the horn/strobe.
4. Run a cable or wires in conduit from the horn/strobe to the Beacon 410 through the left conduit hub.
5. Connect the wires to the strobe terminal strip as shown in the figure below.

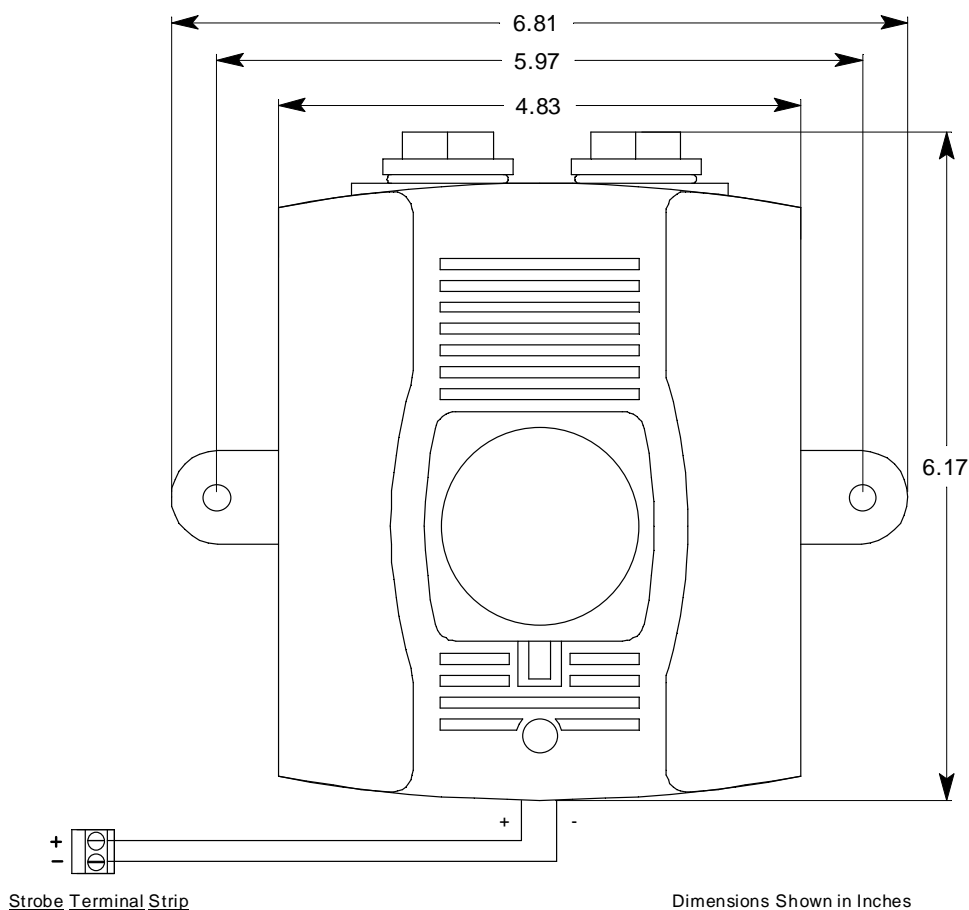

Figure 6: Horn/Strobe Wiring/Outline and Mounting Dimensions

Chapter 3: Installation and Start Up

Overview

This chapter describes procedures to mount the Beacon 410 Gas Monitor, make wiring connections to the monitor, and start up the monitor.

WARNING: *Perform all installation and start-up procedures in a known fresh air environment, an environment free of combustible and toxic gasses and of normal oxygen content. The Beacon 410 is not in operation as a gas monitoring controller until the start up procedure is complete.*

Mounting the Beacon 410 Gas Monitor

Perform the following procedure to install the Beacon 410 at the mounting site.

1. Select the mounting site. When you select the mounting site, consider the following factors:
 - Is an AC or DC power source available?
 - Is a vertical surface available to mount the Beacon 410?
 - Is there enough room to open the housing door and make wiring connections through the conduit hubs at the bottom of the housing?
 - Are the display screen and status lights visible?
2. Close and latch the housing door.
3. The Beacon 410 is shipped with the mounting feet positioned under the housing. Loosen the screws that secure the feet to the housing, rotate the feet to their mounting position as shown in Figure 7, then tighten the screws.
4. Prepare the selected mounting site as required to mount the Beacon 410. It should be mounted at eye level (4 1/2 to 5 feet from the floor). Refer to Figure 7 for the outline and mounting dimensions.
5. Position the monitor on the vertical mounting surface.
6. Insert 1/4 in. screws through the slots in the mounting feet at each corner of the housing to secure the housing to the mounting surface.

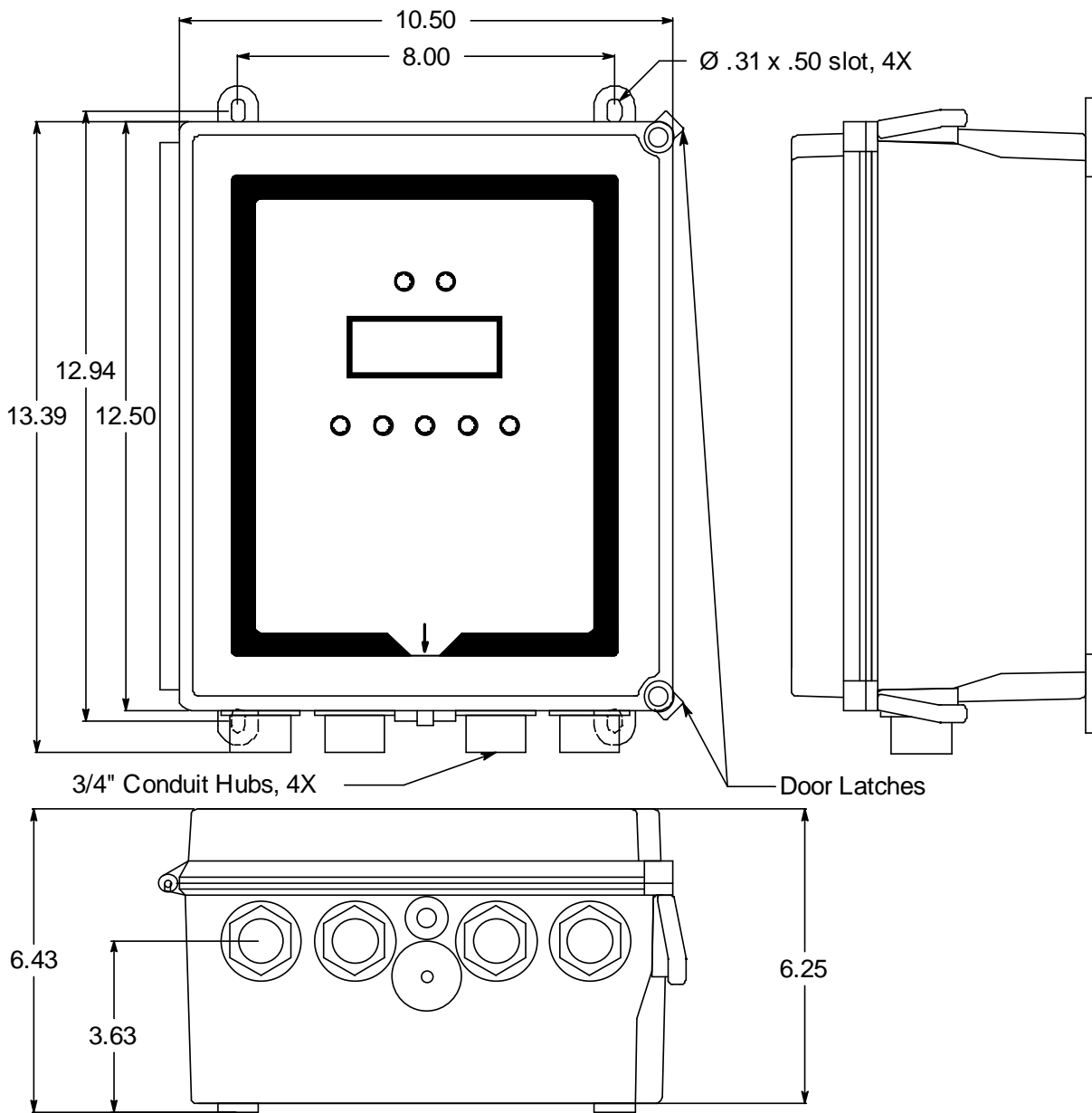

Figure 7: Beacon 410 Gas Monitor Outline and Mounting Dimensions

Wiring the Beacon 410 Gas Monitor

This section describes procedures to connect the AC power source, DC power source, Modbus wiring (refer to "Wiring the Beacon 410 in a Modbus System" on page 54), external alarms, recording devices, and detector heads. See Figure 8 on page 16 for a general diagram of all external wiring to the Beacon 410.

WARNING: *Make all connections to the Beacon 410 before you plug in or turn on the AC or DC power source. Before you make any wiring adjustments, always verify that all power sources are not live.*

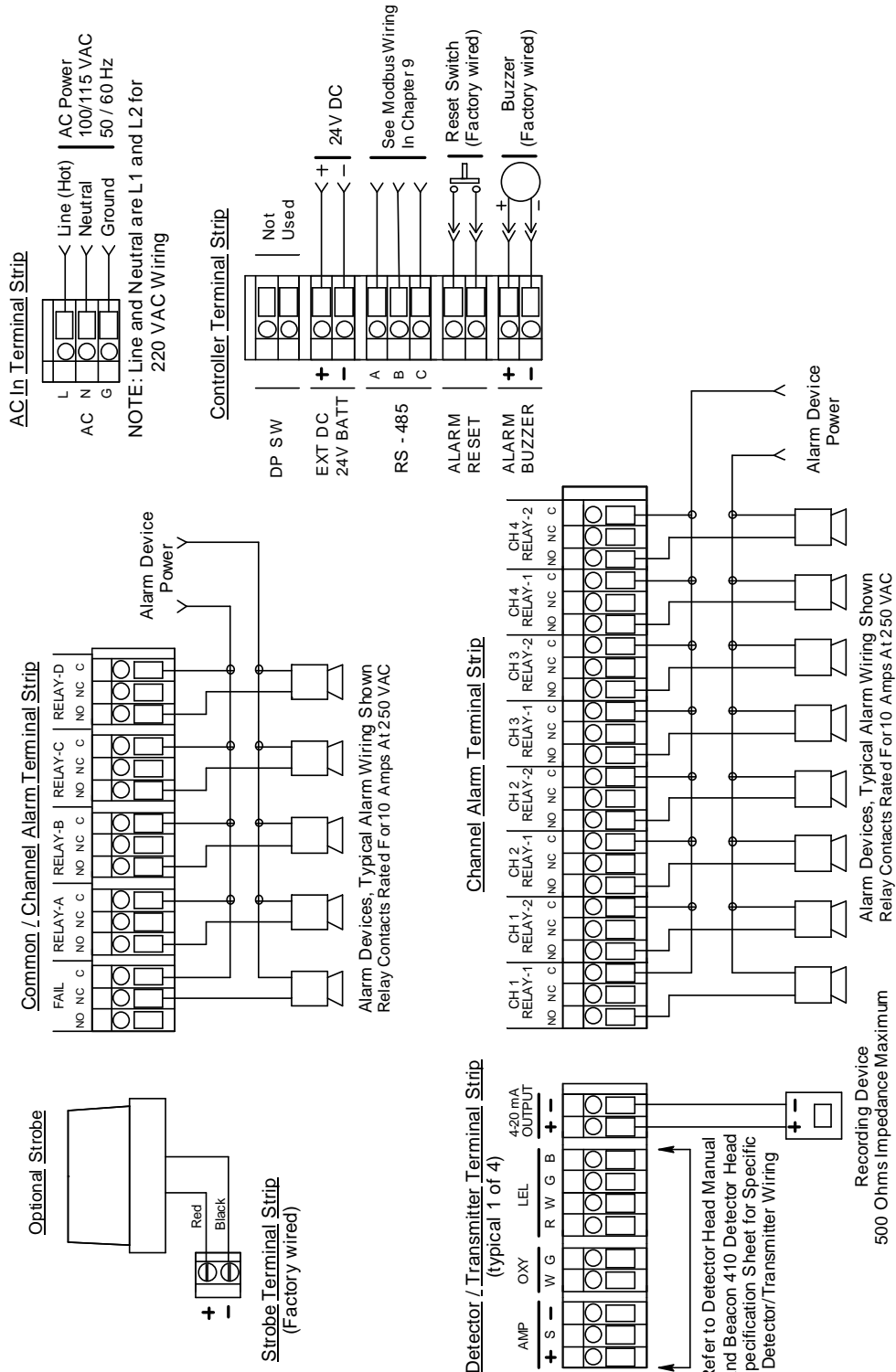

Figure 8: Beacon 410 Gas Monitor External Wiring Diagram

Connecting the AC Power Source

NOTE: If you are using DC power as the primary power source, go to the next section, “Connecting the DC Power Source”.

The AC in terminal strip will accept 24 - 14 AWG wire. When selecting wire to connect the AC power source to the Beacon 410, be sure to meet the local electrical code. Also be sure to use an appropriate circuit breaker in the AC line close to the Beacon 410 that meets the local electrical code.

Perform the following procedure to connect the AC power source to the Beacon 410.

WARNING: *Verify that the power source is unplugged or turned off before you continue with this procedure.*

1. Turn off or unplug all incoming power to the Beacon 410.
2. Open the housing door, then place the power switch in the OFF position.

CAUTION: *The power switch does not control DC input power.*

3. Locate the AC in terminal strip (see Figure 1 on page 5). The terminals are labelled **L**, **N**, and **G** for line, neutral, and ground respectively.
4. Install an appropriately rated cable bushing or conduit in the right-most conduit hub on the bottom of the Beacon 410 housing.
5. Guide the AC power cord or wires in conduit through the right-most conduit hub on the bottom of the Beacon 410 housing.

CAUTION: *Do not route power and detector head wiring through the same conduit hub. The power wiring may disrupt the transmission of the detector head signal to the monitor.*

6. Connect the AC wires to the AC in terminal strip as shown in Figure 9 below.

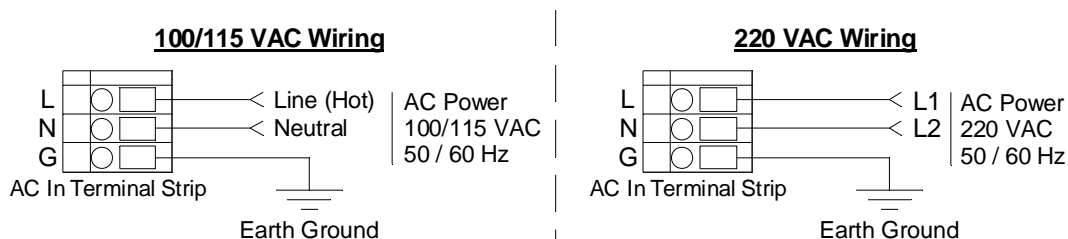

Figure 9: AC Power Wiring

Connecting the DC Power Source

WARNING: *Verify that the power source is unplugged or turned off before you continue with this procedure.*

DC power may be used as a primary power source. It may also be used as a backup power source with a 24 VDC battery if AC power is the primary power source. If your

Beacon 410 does not include the battery charging feature, you may use a self contained 24 VDC backup that keeps its' batteries charged while AC power is on and recharges the batteries when AC power returns after a power failure. If your Beacon 410 includes the battery charging feature, see "Battery Charging (Optional)" on page 25 for a complete description of this feature and what type of battery to use. If DC power is the **primary** power source, **DO NOT** connect AC power.

1. Turn off or unplug all incoming power to the Beacon 410.
2. Open the housing door, then place the power switch in the OFF position.

CAUTION: *The power switch does not control DC input power.*

3. Locate the DC input power terminals on the controller terminal strip near the lower right edge of the main PCB (see Figure 1 on page 5). They are labelled **EXT DC/24V BATT+** and **EXT DC/24V BATT -**.
4. Install an appropriately rated cable bushing or conduit in an unused conduit hub on the bottom of the Beacon 410 housing.
5. Guide a DC power cord or two wires in conduit through the selected conduit hub on the bottom of the Beacon 410 housing.

CAUTION: *Do not route power and detector head wiring through the same conduit hub. The power wiring may disrupt the transmission of the detector head signal to the monitor.*

6. Connect the DC power wires to the controller terminal strip as shown in Figure 10 below.

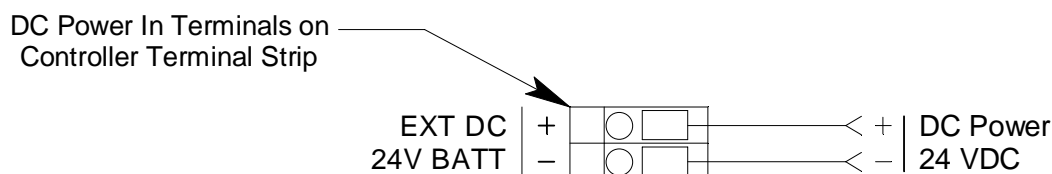

Figure 10: DC Power Wiring

NOTE: The Beacon 410 will operate from the DC input down to 18.5 volts. If a self contained backup battery is used, see its operator's manual for a description of its recharging characteristics. If your Beacon 410 includes the battery charging feature and a backup battery is used, the Beacon 410 will recharge the battery when AC power has returned after a power failure. See "Battery Charging (Optional)" on page 25 for a complete description of the battery charging feature.

RS-485 Modbus Wiring

See "Wiring the Beacon 410 in a Modbus System" on page 54 for wiring connections to the RS-485 Modbus terminals.

Connecting External Alarms

Before connecting any external alarm devices to the relay contacts, make sure you know how you want the devices to operate. For example, confirm under what alarm condition you want a device to turn on or turn off and what channel is going to control the device. Also make sure that the parameter settings that apply to the relays in the Global Menu and the Configuration Menu are set so that the desired alarm device operation is obtained. See “Viewing and Changing Global Parameters” on page 32 and “Viewing and Changing Channel Parameters” on page 35 for information about the relay parameters.

Perform the following procedure to connect external alarm devices to the Beacon 410.

1. Turn off or unplug all incoming power to the Beacon 410.
2. Open the housing door, then place the power switch in the OFF position.

CAUTION: *The power switch does not control DC input power.*

3. Locate the applicable alarm terminal strip (see Figure 1 on page 5).
4. Install an appropriately rated cable bushing or conduit in an unused conduit hub on the bottom of the Beacon 410.
5. Guide the wiring of the external alarm device through the selected conduit hub on the bottom of the Beacon 410 housing.

CAUTION: *Do not route the external alarm wiring and detector head wiring through the same conduit hub. The external alarm wiring may disrupt the transmission of the detector head signal to the Beacon 410.*

6. Connect the leads from the external alarm device and an external power source to the selected channel alarm or common/channel alarm relay contact terminals as shown in Figure 8.

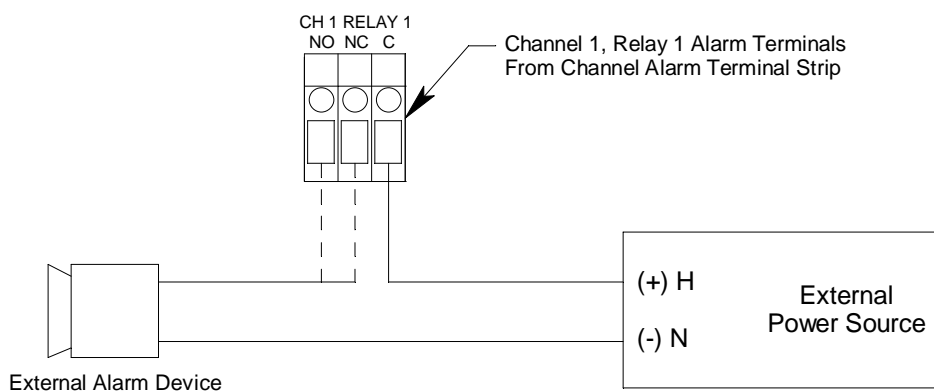

Figure 11: External Alarm Wiring

7. Repeat step 5 and step 6 for additional external alarm devices.

Connecting Recorders

Perform the following procedure to connect an analog signal recording device to the Beacon 410. The output at the recorder output terminals for each channel is a 4 - 20 mA signal that corresponds to the detection range of the detector head connected to that Beacon 410 channel. Be sure to read the recording device's operator's manual before installation and follow all wiring procedures and recommendations made by the recording device's manufacturer.

1. Turn off or unplug incoming power to the Beacon 410.
2. Open the housing door, then place the power switch in the OFF position.

CAUTION: *The power switch does not control DC input power.*

3. Locate the recorder output terminals on the right end of the detector/transmitter terminal strips. See "Beacon 410 Gas Monitor Component Location" on page 5 to assist you in locating the recorder output terminals. They are labelled **4 - 20 mA OUTPUT +** and **4 - 20 mA OUTPUT -**.
4. Install an appropriately rated cable bushing or conduit in an unused conduit hub on the bottom of the Beacon 410 housing.
5. Guide the wiring from the recording device through the selected conduit hub on the bottom of the Beacon 410 housing.
6. Connect the leads from the recording device to the recorder output terminals of the selected active channels as shown in Figure 12 below.

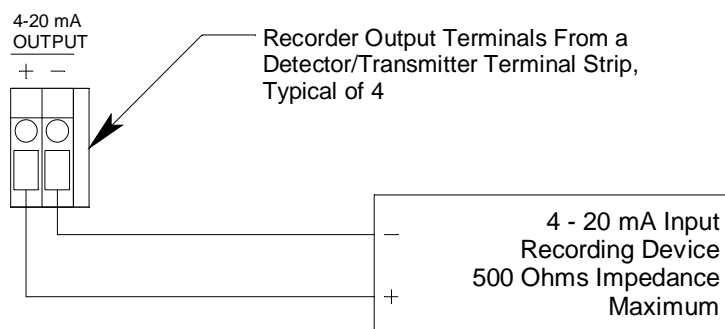

Figure 12: Recorder Output Wiring

Connecting RKI Detector Heads

When a Beacon 410 is ordered from the factory, any detector heads that were ordered with it are already setup on particular channels of the Beacon 410. If you are adding an RKI detector head to your existing system, you will need to setup one of the unused channels to operate the detector head. See "Selecting the Detector Head Input Type and Gas Setup" on page 41 for instructions to setup a new channel.

Perform the following procedure to connect an RKI detector head to the Beacon 410.

1. Turn off or unplug power to the Beacon 410.
2. Open the Beacon 410 door and place the power switch in the off position.

CAUTION: *The power switch does not control DC input power.*

3. See the detector head operator's manual for instructions on how to connect the

detector head to a controller.

4. Install an appropriately rated cable bushing or conduit in an unused conduit hub on the bottom of the Beacon 410 housing.
5. Route the wires in conduit or shielded cable from the detector head through the selected conduit hub into the Beacon 410. See Table 4 below for wire size and distance guidelines.
6. Unshielded twisted pair cable in conduit or shielded twisted pair cable is recommended for all the direct connect detector heads. For the LEL detector, pair and twist the **R & B** wires and the **W & G** wires. Shielded cable or wires in conduit are recommended for the 2-wire and 3-wire 4 - 20 mA transmitters.
7. Connect the wires from the detector head to the appropriate detector/transmitter terminals on the appropriate channel. See the detector head operator's manual and the Beacon 410 Detector Head Specification Sheet for detector head connections to the Beacon 410. If shielded cable is used, leave the cable shield's drain wire disconnected and insulated at the detector head and connect the cable shield's drain wire at the Beacon 410 to the ground stud on the main PCB.

CAUTION: *Do not route power and detector head wiring through the same conduit hub. The power wiring may disrupt the transmission of the detector head's signal to the Beacon 410.*

Table 4: Wire Size Guidelines for RKI Detector Head Wiring

Detector Head Type	Number of Wires to Controller	Max Distance to Controller w/18 Gauge Wire	Max Distance to Controller w/16 Gauge Wire	Max Distance to Controller w/14 Gauge Wire
Direct Connect LEL	4	500 ft.	1,000 ft.	2,000 ft.
Direct Connect Oxygen	2	500 ft.	1,000 ft.	2,000 ft.
Direct Connect H ₂ S	2	500 ft.	1,000 ft.	2,000 ft.
Direct Connect CO	2	500 ft.	1,000 ft.	2,000 ft.
Direct Connect ESM-01 type	2	500 ft.	1,000 ft.	2,000 ft.
2-Wire 4 - 20 mA Transmitter	2	2,500 ft.	5,000 ft.	8,000 ft.
3-Wire 4 - 20 mA Transmitter	3	2,500 ft.	5,000 ft.	8,000 ft.

Connecting User-Supplied 4 - 20 mA Transmitters

The Beacon 410 may be used with a user supplied 2-wire or 3-wire 4 - 20 mA transmitter which runs on 24 VDC. When this is done, the Beacon 410 is normally setup at RKI Instruments with the following channel parameters: unit of measure, item name, and full scale. For example, "PSI AIR" with a full scale of 10 PSI.

If a user supplied 4 - 20 mA transmitter is added in the field, it will be necessary to setup the additional channel. See "Selecting the Detector Head Input Type and Gas Setup" on

page 41 for instructions to setup a new channel.

Perform the following procedure to connect a 4 - 20 mA transmitter which you supply to the Beacon 410.

1. Turn off or unplug power to the Beacon 410.
2. Open the Beacon 410 door and turn off the power switch.

CAUTION: *The power switch does not control DC input power.*

3. See the transmitter's operator's manual for instructions on how to connect wires to the transmitter.
4. Install an appropriately rated cable bushing or conduit in an unused conduit hub on the bottom of the Beacon 410 housing.
5. Route the wires from the transmitter through the selected conduit hub into the Beacon 410.
6. Connect the wires from the transmitter to the appropriate channel's detector/transmitter terminal strip. See the transmitter operator's manual for controller terminal connections and wiring recommendations.

CAUTION: *Do not route power and transmitter wiring through the same conduit hub. The power wiring may disrupt the transmission of the transmitter's signal to the Beacon 410.*

Figure 13 below illustrates typical transmitter wiring connections.

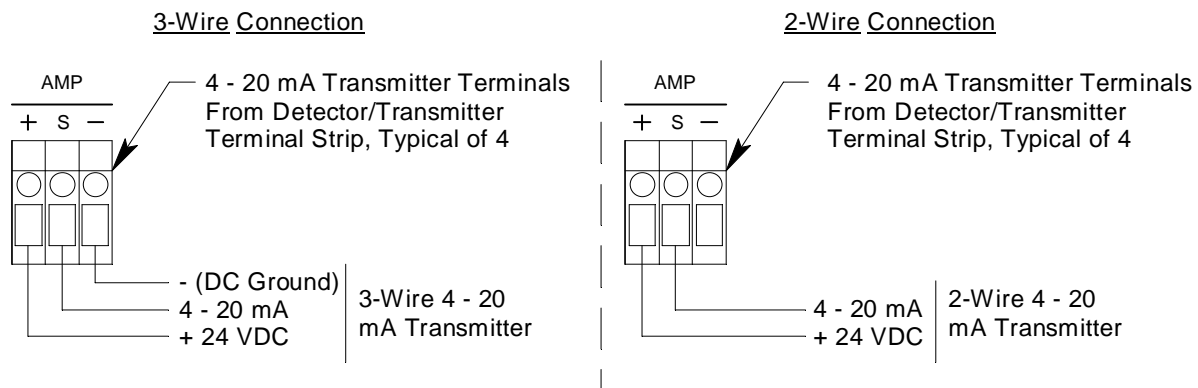

Figure 13: Generic 4 to 20 mA Transmitter Wiring

Starting Up the Beacon 410 Gas Monitor

Perform the following procedure to place the Beacon 410 into normal operation.

1. Complete the mounting and wiring procedures described earlier in this chapter.
2. Complete all installation procedures described in the detector head or user supplied 4 - 20 mA transmitter operator's manuals.
3. Verify that all wiring connections are correct and secure and that the Beacon 410's power switch is in the OFF position.

4. Plug in or turn on the incoming power source (AC or DC).
5. Turn on the power switch if AC power is used as primary power.
6. The following screen appears for a few seconds.

```

R K I   I n s t r u m e n t s
B e a c o n   4 1 0

```

7. The Version Screen then appears. It shows the instrument's hardware and firmware versions for a few seconds. HW is the hardware version. Main is the main firmware version. MB is the Modbus firmware version. The version numbers on the bottom line are the firmware versions loaded for each channel.

```

          V E R S I O N   I N F O
H W :    0 0 0 0
M a i n :    0 0 0 1      M B :    0 0 0 1
          0 0 0 1   0 0 0 1   0 0 0 1   0 0 0 1

```

To keep the version information screen on the display longer than a few seconds, press and hold the ENTER button while it is being displayed. When you release the ENTER button, the startup sequence will continue.

8. After the Version Screen has been displayed for a few seconds, **WARMING UP** appears for each active channel. The warm-up time is counted down in seconds from 60 seconds for each active channel on the far right.

NOTE: To prevent unwanted alarms during warm up, the alarm circuits are not active while the **WARMING UP** message is displayed.

9. Any unused channels are configured as **NOT USED** in the Configuration Menu at the factory. For any unused channels, **NOT USED** is displayed on the line for that channel.
If any channels have been configured as **STANDBY** in the Configuration Menu, **STANDBY** is displayed on the line for that channel.
See "Viewing and Changing Channel Parameters" on page 35 for a description of the **NOT USED** and **STANDBY** configurations.
10. When the warm-up period is complete, normal operation will begin. During normal operation, the display will indicate the current gas reading and target gas. Verify that the display is indicating the current gas reading and target gas for all active channels after the warm-up period is complete and normal operation begins, for example:

```

1 :   M E T H A N E           0   % L E L
2 :   O X Y G E N           2 0 . 9   % V O L
3 :   H 2 S                 0   p p m
4 :   C O                   0   p p m

```

11. Verify that the PILOT light is on. If the PILOT light is not on, see the troubleshooting guide in "Troubleshooting" on page 64.
12. Perform the start-up procedure for each detector head or user supplied 4 - 20 mA transmitter as described in the detector head or user supplied transmitter's operator's manual.

Chapter 4: Operation

Overview

This chapter describes the Beacon 410 Gas Monitor in normal operation. This chapter also describes the Beacon 410 in alarm 1, alarm 2, alarm 3, and fail conditions, and suggests responses to these conditions.

Normal Operation

Normal operation is defined as follows:

- the start-up procedure is complete.
- the Beacon 410 is not indicating an alarm 1, alarm 2, alarm 3, or fail condition.
- the Beacon 410 is not running in one of the selection menus or Calibration Mode.

During normal operation, the Beacon 410 simultaneously displays the target gas, unit of measure, and current gas reading for all active channels. The example below illustrates a typical Beacon 410 channel allocation.

1	:	M E T H A N E		0	% L E L
2	:	O X Y G E N	2 0 . 9		% V O L
3	:	H 2 S		0	p p m
4	:	C O		0	p p m

The PILOT LED is on indicating that the Beacon 410 is receiving incoming power.

4 - 20 mA Signal Output Operation

The output at the recorder output terminals on the detector/transmitter terminal strip for each channel is a 4 - 20 mA signal that corresponds to the detection range of the Beacon 410. During normal operation, this signal tracks the gas concentration on the LCD.

There are several circumstances where the signal output will not track the display reading but will behave as follows:

- When the Beacon 410 is in its warm-up period, the signal output will be fixed at 4 mA (zero) for all channel types except oxygen. For oxygen channels, the output will be fixed at 17.4 mA (20.9% oxygen) while the Beacon 410 is in warm-up.
- When a channel's input type is changed to a new direct connect type of detector head in the Input Setup Menu, the display will indicate **NEEDS AIR/GAS Cal** for that channel when you exit the Input Setup Menu and enter normal operation and will continue to indicate this until Calibration Mode is entered and a calibration is performed. If a custom gas name and range was defined in the Input Setup Menu, the Beacon 410 will enter the Configuration Menu for you to verify the parameter settings before continuing to the normal operation and displaying the **NEEDS AIR/GAS Cal** message. In this situation, the signal output for the newly configured channel will be fixed at 0.7 mA until a complete calibration is performed on that channel.

- If you enter the Global Menu, the Configuration Menu, the Input Setup Menu, the Modbus Menu, or Calibration Mode, the signal output will be fixed at 3.5 mA until the Beacon 410 returns to normal operation.
- If the Beacon 410's input power decreases below 18.5 volts so that the Beacon 410 is in a low power alarm, the signal output is fixed at 0.7 mA until the low power alarm is cleared.
- If the Beacon 410 goes into a fail condition, after a 30 second delay, the signal output is fixed at 0.7 mA until the fail alarm is cleared. During the 30 second delay, the output follows the detector output.
- If a channel is setup as **NOT USED**, the signal output will be fixed at about 0.7 mA.
- If a channel is setup as **STANDBY**, the signal output will be fixed at 3.5 mA.

Viewing and Resetting Min/Max Readings

The Reset switch may be used to view and reset the minimum and maximum gas readings for all active channels.

1. While the Beacon 410 is in normal operation, press and hold the reset switch button for 5 seconds.
2. The display will show the following screen for about ten seconds.

1 :	0	0
2 :	2 0 . 9	2 0 . 9
3 :	0	0
4 :	0	0

The minimum reading is on the left and the maximum is on the right for each channel.

3. After the minimum and maximum readings have been displayed for about ten seconds, the following screen appears for about seven seconds.

P	u	s	h	R	e	s	e	t	A	g	a	i	n	T	o		
R	e	s	e	t	M	i	n	/	M	a	x	V	a	l	u	e	s
O	r	W	a	i	t	T	o	R	e	t	u	r	n	T	o		
N	o	r	m	a	l	O	p	e	r	a	t	i	o	n			

- To reset the minimum and maximum readings, before the unit returns to normal operation press and release the reset switch button. The display indicates **Min/Max Values Have Been Reset** and the unit will then return to normal operation.
- To return to normal operation without resetting the minimum and maximum readings, do not press the reset switch button and allow the unit to return to normal operation.

Battery Charging (Optional)

The Beacon 410 has an optional backup battery charging feature. In order for this feature to be included, the Beacon 410 must be ordered with this feature. Consult RKI Instruments, Inc. for ordering information.

The battery charging circuit is designed to charge lead acid type batteries. If AC power is used as primary power and a backup battery is connected to the Beacon 410 's EXT DC/ 24V BATT terminals as shown in Figure 10 on page 18, the battery charging feature will charge the battery if it is depleted and keep it charged with a charge current of approximately 100 mA.

CAUTION: *When a battery is used as backup power and the charging feature is included in the Beacon 410, do not use a non-rechargeable battery or a backup battery that has it's own charging feature. Use RKI backup battery 49-8104RK or an appropriately rated 24 VDC rechargeable lead acid type battery to backup a Beacon 410 when the battery charging feature is included in the Beacon 410.*

Alarm Indications

This section describes the Beacon 410 in alarm 1, alarm 2, alarm 3 and fail conditions, and suggests responses to these conditions. Table 5 below lists the alarm indications for each condition.

NOTE: The Beacon 410 allows configuration of various alarm and alarm relay parameters. The description of alarm indications below assumes that all parameters are at their factory set value. It also assumes that the alarm setpoints are set such that alarm 1 < alarm 2 < alarm 3 and all alarms are increasing except for an oxygen channel where alarm 1 > alarm 3 and alarm 2 > alarm 3 because alarm 1 and alarm 3 are decreasing alarms and alarm 2 is an increasing alarm.

See "Viewing and Changing Channel Parameters" on page 35 for detailed information on displaying or changing various channel parameters including alarm and alarm relay parameters. Table 7 on page 37 lists the adjustable parameters and their factory settings.

Table 5: Visual and Audible Alarm Indications

Condition	Cause	Visual Indication(s)	Audible Indication
Alarm 1	Increasing (decreasing for O ₂) gas reading at or above the alarm 1 setpoint	<ul style="list-style-type: none"> Alarm 1 LED is on Gas reading alternates with ALARM-1 message If installed and set to activate for alarm 1, strobe flashes 	Pulsing Tone
Alarm 2	Increasing gas reading at or above the alarm 2 setpoint	<ul style="list-style-type: none"> Alarm 1 and alarm 2 LEDs (alarm 2 only for oxygen) are on Gas reading alternates with ALM 1,2 message (ALARM-2 for oxygen) If installed, strobe continues to flash if set to activate for alarm 1. If set to activate for alarm 2 only or if channel in alarm is an oxygen channel, it begins to flash when an alarm 2 condition begins. 	Pulsing Tone

Table 5: Visual and Audible Alarm Indications

Condition	Cause	Visual Indication(s)	Audible Indication
Alarm 3	Increasing (decreasing for O ₂) gas reading at or above (below for O ₂) the alarm 3 setpoint	<ul style="list-style-type: none"> Alarm 1, alarm 2, and alarm 3 LEDs (alarm 1 and alarm 3 for oxygen) are on Gas reading alternates with ALM 1,2,3 (ALM 1,3 for oxygen) message If installed, strobe continues to flash if set to activate for alarm 1 and/or alarm 2 for non oxygen type channels or alarm 1 for oxygen channels. If set to activate for alarm 3 only, it begins to flash when an alarm 3 condition begins. 	Pulsing tone
Fail	<ul style="list-style-type: none"> Disconnected or misconnected detector head wiring Display reading below -10% of full scale or lower Malfunctioning components 	<ul style="list-style-type: none"> Fail LED is on FAIL message replaces the gas reading If installed and set to activate for fail, strobe flashes <p><i>NOTE: There is a 30 second delay on the fail indications.</i></p>	Steady tone
Low Battery	No AC power and DC power source (primary or backup) less than 18.5 volts.	<ul style="list-style-type: none"> FAIL LED is on Display shows LOW POWER STANDBY message and the input DC voltage 	None

NOTE: You can set the channel alarm relays and the common/channel alarm relays (relays A, B, C, and D) to be either all normally energized or all normally de-energized in the Global Menu. You can also set relays A, B, C, and D as common alarm relays or channel alarm relays in the Global Menu. The following sections describe the factory settings of normally de-energized for the channel and common/channel relays (A, B, C, and D) and common alarm relays for relays A, B, C, and D. The fail relay is factory-set as normally energized and is not user adjustable. See “Viewing and Changing Global Parameters” on page 32 for instructions to change the setup of relays A, B, C, and D.

Alarm 1 Condition

This section describes the indications for an alarm 1 condition and suggests responses to an alarm 1 condition.

Alarm 1 Condition Indications

When the gas reading of an active channel reaches the alarm 1 setpoint, the Beacon 410 senses an alarm 1 condition. The Beacon 410 alerts you to an alarm 1 condition as follows:

- the alarm 1 LED turns on
- the gas reading in alarm 1 condition alternates with the **ALARM-1** message
- the buzzer sounds a pulsing tone
- the common alarm 1 relay (relay A) and relay D energize

NOTE: Relay D is factory set as a common any alarm relay.

- the applicable alarm 1 channel relay energizes
- if installed and set to activate in an alarm 1 condition, the strobe flashes

Responding to an Alarm 1 Condition

This section suggests the following responses to an alarm 1 condition:

1. Follow your established procedure for a low-level combustible or toxic gas condition or a decreasing oxygen condition.
2. To acknowledge the alarm condition and silence the buzzer while in an alarm 1 condition, press and release the reset switch. The alarm 1 LED will begin to flash indicating the alarm condition has been acknowledged. You cannot de-energize the alarm 1 relays until the gas reading falls below (rises above for oxygen) the alarm 1 setpoint.
3. Oxygen alarms are factory set as self-resetting and will automatically clear when the oxygen reading rises above the alarm 1 setpoint.
4. Alarms for all other gas types are factory set as latching. After the gas reading falls below the alarm 1 setpoint, press and release the reset switch to reset the alarm 1 circuit. Resetting the alarm 1 circuit silences the buzzer (if the alarm has not been acknowledged), turns off the alarm 1 LED, resets the display for the channel(s) in alarm, turns off the strobe if it is installed and set to activate for alarm 1, and de-energizes the common and channel alarm 1 relays and relay D.

Alarm 2 Condition

This section describes the indications for an alarm 2 condition and suggests responses to an alarm 2 condition.

Alarm 2 Condition Indications

When the gas reading of an active channel reaches the alarm 2 setpoint, the Beacon 410 senses an alarm 2 condition. The Beacon 410 alerts you to an alarm 2 condition as follows:

- the ALARM 2 LED turns on
- the gas reading during an alarm 2 condition alternates with the **ALM 1,2 (ALARM-2)** for oxygen) message
- the buzzer sounds a pulsing tone
- the common alarm 2 relay (relay B) energizes
- for an oxygen channel, relay D energizes (it is already energized for non-oxygen channels)
- the applicable alarm 2 channel relay energizes
- if installed and set to activate for alarm 1, the strobe continues to flash for non-oxygen channels
- if installed and set to activate for alarm 2 only or for oxygen channels, the strobe begins to flash when an alarm 2 condition begins

Responding to an Alarm 2 Condition

This section suggests responses to an alarm 2 condition.

1. Follow your established procedure for a high-level combustible or toxic gas condition,

or an increasing oxygen condition.

2. To acknowledge the alarm condition and silence the buzzer while in an alarm 2 condition, press and release the reset switch. The alarm 2 LED will begin to flash indicating the alarm condition has been acknowledged. You cannot de-energize the alarm 2 relays until the gas reading falls below the alarm 2 setpoint.
3. Oxygen alarms are factory set as self-resetting and will automatically clear when the oxygen reading falls below the alarm 2 setpoint.
4. Alarms for all other gas types are factory set as latching. After the gas reading falls below the alarm 2 setpoint, press and release the reset switch to reset the alarm circuit. Resetting the alarm circuit silences the buzzer (if the alarm has not been acknowledged) turns off the alarm 2 LED, resets the display for the channel(s) in alarm, turns off the strobe if it is installed and set to activate for alarm 2 only or if a channel is an oxygen channel, and de-energizes the common and channel alarm 2 relays. For oxygen channels, the reset switch also de-energizes relay D.

Alarm 3 Condition

This section describes the indications for an alarm 3 condition and suggests responses to an alarm 3 condition.

NOTE: The factory set configuration of the Beacon 410 does not assign channel relay contacts to the alarm 3 condition. Relays A, B, C, and D are factory set as common alarm relays, but can be configured as channel alarm 3 relays. See “Viewing and Changing Global Parameters” on page 32 and “Viewing and Changing Channel Parameters” on page 35 for instructions to change relays A, B, C, and D from their factory setting.

Alarm 3 Condition Indications

When the gas reading of an active channel reaches the alarm 3 setpoint, the Beacon 410 senses an alarm 3 condition. The Beacon 410 alerts you to an alarm 3 condition as follows:

- the alarm 3 LED turns on;
- the gas reading during an alarm 3 condition continues to flash and alternates with the **ALM 1,2,3** (**ALM 1,3** for oxygen) message;
- the buzzer sounds a pulsing tone;
- the common alarm 3 relay (relay C) energizes
- if installed and set to activate for alarm 1 and/or alarm 2 for non-oxygen channels or alarm 1 for oxygen channels, the strobe continues to flash
- if set to activate for alarm 3 only, it begins to flash when an alarm 3 condition begins

Responding to an Alarm 3 Condition

This section suggests responses to an alarm 2 condition.

1. Follow your established procedure for a high-level combustible or toxic gas condition, or an increasing oxygen condition.
2. To acknowledge the alarm condition and silence the buzzer while in an alarm 3 condition, press and release the reset switch. The ALARM 3 LED will begin to flash indicating the alarm condition has been acknowledged. You cannot de-energize the

common alarm 3 relay (relay C) until the gas reading falls below the alarm 3 setpoint.

3. Oxygen alarms are factory set as self-resetting and will automatically clear when the oxygen reading rises above the alarm 3 setpoint.
4. Alarms for all other gas types are factory set as latching. After the gas reading falls below the alarm 3 setpoint, press and release the reset switch to reset the alarm circuit. Resetting the alarm circuit silences the buzzer (if the alarm has not been acknowledged) turns off the ALARM 3 LED, and de-energizes the common alarm 3 relay.

Fail Condition

This section describes the indications for a fail condition and suggests responses to a fail condition.

Fail Condition Indications

The Beacon 410 senses a fail condition for any of the following:

- the detector head wiring is disconnected or incorrectly connected;
- the display reading is -10% of full scale or lower;
- the Beacon 410 or one of its detector heads is malfunctioning.

When the Beacon 410 senses a fail condition, it alerts you as follows:

- the fail LED turns on;
- the gas reading for the failing channel is replaced by the **FAIL** message;
- the buzzer sounds a steady tone;
- the common fail relay de-energizes.

NOTE: The fail alarm has a 30 second delay.

NOTE: If you elect to use relays A, B, C, and D as channel fail relays in the Configuration Menu, the appropriate relay de-energizes in a fail condition. Relays A, B, C, and D correspond to channels 1, 2, 3, and 4. See “Viewing and Changing Channel Parameters” on page 35 for a instructions to define channel fail relays.

Responding to a Fail Condition

This section suggests responses to a fail condition.

1. Verify that the detector head wiring is correctly and securely connected.
2. See the troubleshooting guide in “Troubleshooting” on page 64.

Low DC Power Condition

This section describes the audible and visual indications for a low DC power condition and suggests responses to a low DC power condition. This condition only occurs when DC power is used as the primary or a backup power source

Low DC Power Condition Indications

The Beacon 410 senses a DC low power condition when the DC power source is 18.5 volts or less.

WARNING: While in a low power condition, the Beacon 410 is not an active gas monitor.

When the Beacon 410 senses a low DC power condition, it alerts you as follows:

- The FAIL LED turns on.
- The fail relay and all other relays are de-energized.
- The message **LOW POWER S STANDBY** is indicated on the top line of the LCD and the input voltage is displayed on the bottom line of the LCD.

NOTE: The low DC power alarm cannot be cleared using the reset switch.

When the DC input voltage increases to 19.0 volts, the low DC power alarm is cleared and the Beacon 410 will begin its warm-up sequence.

Responding to a Low DC Power Condition

- If DC power is the **primary** power source:
 1. For a *temporary* DC power source, disconnect primary DC power at the Beacon 410, then connect a 24 VDC battery.
 2. Determine and correct the cause of primary DC power loss. When the DC power source rises above 19.0 volts, the Beacon 410 begins the warm up process.
 3. Verify that the Beacon 410 enters normal operation after its warm-up sequence.
- If DC power is the **backup** power source:
 1. If a non-rechargeable battery is used for backup, replace the battery.
 2. Determine and correct the cause of primary AC power loss. When backup DC or primary AC power is restored, the Beacon 410 begins the warm up process.

If the Beacon 410 was purchased with the battery charging feature, when AC power is restored, the Beacon 410 charges the backup battery with a charge current of approximately 100 mA until it is fully recharged. Charge time varies depending on the battery size and how much the battery was depleted. Once the battery is fully charged, the Beacon 410 maintains the charge with the 100 mA charge current.

3. Verify that the Beacon 410 enters normal operation after its warm-up sequence.

Chapter 5: Global Menu

Overview

This chapter describes how to view and change Beacon 410 instrument parameters using the Global Menu. The global parameters are the optional strobe's installation setting, the relay normal state setting, the usage setting for relays A, B, C, and D, and the buzzer silence setting. The Global Menu is accessed using the ESCAPE and UP/YES control buttons.

The Global Menu includes a 5-minute timeout feature. If you do not press a control button for 5 minutes, the Beacon 410 automatically returns to normal operation.

NOTE: If the Beacon 410 returns to normal operation because of a timeout, it enters a warm-up period just as it does when it is first turned on.

If you are installing a new Beacon 410, it has been set up at the factory. Use the Global Menu only if you want to change the instrument parameter factory settings.

Viewing and Changing Global Parameters

WARNING: *The Beacon 410 is not an active gas monitoring device while in the Global Menu. When you enter the Global Menu, the 4-20 mA output signal will “freeze” at 3.5 mA for each active channel, all relays and alarm LEDs will remain in their current state at the time that you entered the Global Menu, and the alarm buzzer and strobe will turn off if they were activated until you exit the Global Menu. The 4 - 20 mA output signal will not indicate current readings and the relays and alarm LEDs will not resume operating normally until the Beacon 410 is in normal operation again.*

NOTE: You must set the instrument parameters to the desired settings using the Global Menu before making any changes to the channel parameters in the Configuration Menu. Settings in the Global Menu influence what channel parameters appear in the Configuration Menu.

1. While in Normal Operation, press and hold the ESCAPE and UP/YES buttons for approximately 5 seconds to enter the Global Menu. Release the buttons when the **You Have Entered the GLOBAL Menu** message appears.
2. Press and release the UP/YES button to continue in the Global Menu to the first global parameter setting screen, the Strobe Installation Screen.

STROBE Installation:

NO STROBE INSTALLED

UP/DN then ENT/ESC

3. In the parameter screens, use the ENTER button to accept a displayed parameter setting and proceed to the next parameter or the ESCAPE button to backup a screen.
4. If you want to change a displayed parameter setting, use the UP/YES or DOWN/NO button to change the parameter to the desired setting, then press and release the ENTER button to accept the change and proceed to the next screen.
5. Continue through the parameter setting screens changing any parameter settings as needed until the following message appears on the display.

```

S a v e   S e t t i n g s ?

[ Y / N ]
[ E S C A P E ]   t o   b a c k   u p

```

6. To save the global parameter settings, press and release the UP /YES button. The screen will indicate that the Beacon 410 is saving the settings for a few seconds then the Beacon 410 will return to normal operation.

If you do not want to save the global parameter settings, press and release the DOWN/NO button. The display will indicate that no settings have been changed for a few seconds then the Beacon 410 will return to normal operation.

Table 6 below lists the global parameters that can be configured in the Global Menu along with the factory set value for each parameter.

Table 6: Global Menu Parameters

Global Parameter (Factory-Set Value)	Description
STROBE Installation (Factory setting depends on whether a strobe is supplied with the Beacon 410.)	If set to STROBE IS INSTALLED , the strobe circuitry is functional and items in the Configuration Menu that apply to the strobe operation become active. If set to NO STROBE INSTALLED , the strobe circuitry does not function and items in the Configuration Menu that apply to the strobe operation do not appear.

Table 6: Global Menu Parameters (Continued)

Global Parameter (Factory-Set Value)	Description
NORMAL RELAY STATES (NORM DE-ENERGIZED)	<p>If set to NORM DE-ENERGIZED, the gas alarm relays are de-energized in normal operation and energize when the appropriate alarm circuit is activated. The NO (normally open) relay contacts are open during non-alarm operation and close when the appropriate alarm condition occurs. The NC (normally closed) relay contacts are closed during non-alarm operation and open when the appropriate alarm condition occurs.</p> <p>If set to NORMALLY ENERGIZED, the gas alarm relays are energized in normal operation and de-energize when the appropriate alarm circuit is activated. The NO (normally open) relay contacts are closed during non-alarm operation and open when the appropriate alarm condition occurs. The NC (normally closed) relay contacts are open during non-alarm operation and close when the appropriate alarm condition occurs.</p> <p>NOTE: The fail relay is factory set as normally energized and is not field adjustable.</p>
RELAYS ABCD used as (COMMON ALARM RELAYS)	<p>If set to COMMON ALARM RELAYS, relays A, B, C, and D are defined as common alarms assigned to the gas alarms as follows:</p> <ul style="list-style-type: none"> Relay A: Common Alarm 1 Relay B: Common Alarm 2 Relay C: Common Alarm 3 Relay D: Common Any alarm <p>If set to CHANNEL ALARM RELAYS, relays A, B, C, and D are defined as configurable channel alarm relays assigned to the detection channels as follows:</p> <ul style="list-style-type: none"> Relay A: Channel 1 Relay B: Channel 2 Relay C: Channel 3 Relay D: Channel 4 <p>Each relay is factory assigned to alarm 3, but this can be changed in the Configuration Menu.</p>
BUZZER SILENCE (CAN SILENCE BUZZER)	<p>If set to CAN SILENCE BUZZER, the buzzer can be silenced by pressing and releasing the reset switch when the Beacon 410 is in a gas alarm condition.</p> <p>If set to CAN'T SILENCE BUZZER, the buzzer cannot be silenced by the reset switch while the Beacon 410 is in a gas alarm condition.</p>

Chapter 6: Configuration Menu

Overview

This chapter describes how to view and change Beacon 410 channel parameters including alarm point settings and channel relay settings using the Configuration Menu. The Configuration Menu is accessed using the ESCAPE and ENTER control buttons.

The Configuration Menu includes a 5-minute timeout feature. If you do not press a control button for 5 minutes, the Beacon 410 automatically returns to normal operation.

NOTE: If the Beacon 410 returns to normal operation because of a timeout, it enters a warm-up period just as it does when it is first turned on.

If you are installing a new Beacon 410, it has been set up at the factory. Use Configuration Mode only if you want to change one or more channel's parameter factory settings. If you want to change a channel's detector type see "Chapter 7: Input Setup Menu" on page 41.

Viewing and Changing Channel Parameters

WARNING: *The Beacon 410 is not an active gas monitoring device while in the Configuration Menu. When you enter the Configuration Menu, the 4-20 mA output signal will "freeze" at 3.5 mA for each active channel, all relays and alarm LEDs will remain in their current state at the time that you entered the Configuration Menu, and the alarm buzzer and strobe will turn off if they were activated until you exit the Configuration Menu. The 4 - 20 mA output signal will not indicate current readings and the relays and alarm LEDs will not resume operating normally until the Beacon 410 is in normal operation again.*

1. While in normal operation, simultaneously press and hold the ESCAPE and ENTER buttons for approximately 5 seconds to enter the Configuration Menu. Release the buttons when the **You Have Entered the CONFIGURATION Menu** message appears on the display.
2. Press and release the UP/YES button to continue in the Configuration Menu to the Select Channel Screen.

S e l e c t C h a n n e l

1

U P / D N t h e n E N T / E S C

3. Use the UP/YES or DOWN/NO buttons to select the channel whose parameters you want to view and/or update, then press and release the ENTER button. The first channel parameter screen appears and it allows you to select whether the channel is set to **ACTIVE**, **STANDBY**, or, **NOT USED**.

4. Press and release the UP /YES or DOWN/NO button until the setting you want to select appears, then press and release the ENTER button to save it. The next channel parameter screen appears.

NOTE: If you selected STANDBY or NOT USED, the display will ask you if you still want to review the channel settings. If yes, press and release the UP/YES button and continue with step 5. If no, press and release the DOWN/NO button and proceed to step 9.

NOTE: Use the ESCAPE button to go backwards in the menu.

5. In the parameter screens, use the ENTER button to accept a displayed parameter setting and proceed to the next parameter or the ESCAPE button to backup a screen.
6. If you want to change a displayed parameter setting, use the UP/YES or DOWN/NO button to change the parameter to the desired setting, then press and release the ENTER button to accept the change and proceed to the next screen.
7. Continue through the parameter setting screens changing any parameter settings as needed until the following message appears on the display.

```
S a v e   S e t t i n g s ?  
[ Y / N ]  
[ E S C A P E ]   t o   b a c k   u p
```

8. To save the channel parameter settings, press and release the UP /YES button. The screen will indicate that the Beacon 410 is saving the settings for a few seconds.

If you do not want to save the channel parameter settings, press and release the DOWN/NO button. The display will indicate that no settings have been changed for a few seconds and the channel parameters will return to their original settings.

9. The following screen will appear asking if you want to configure more channels.

```
D o   Y o u   W a n t   T o  
D o   M o r e   C h a n n e l s ?  
[ Y / N ]
```

If yes, press and release the UP/YES button to return to the Select Channel Screen. Begin at instruction step 3 above to configure another channel.

If no, then press the DOWN /NO button to return to normal operation.

Table 7 below lists the channel parameters that can be viewed and updated in the Configuration Menu along with the factory set value for each parameter.

Table 7: Configuration Menu Parameters

Channel Parameter (Factory-Set Value)	Description
Channel Status (Factory setting depends on whether a detector is supplied for a channel.)	<p>If set to ACTIVE, the channel will be fully functional.</p> <p>If set to STANDBY, the channel's gas name and reading will be replaced by STANDBY on the display. The channel's relays will be fixed in their non-alarm state and the 4 - 20 mA output for the channel will be fixed at 3.5 mA. This setting is typically used when maintenance is being performed on a channel.</p> <p>If set to NOT USED, the channel is not functional and the gas name and reading field for that channel indicates NOT USED. All the channel's relays are de-energized and the 4 - 20 mA output is fixed at about 0.7 mA.</p>
Strobe Setting (USE w/ Alarms Only)	<p>If set to USE w/ Alarms Only, the strobe will activate when the appropriate gas alarm condition occurs as defined in the alarm strobe settings (see below) in the Configuration Menu. It will not operate when a fail alarm occurs.</p> <p>If set to USE w/ Alarms and Fail, the strobe will activate when the appropriate gas alarm condition occurs and when a fail alarm occurs.</p> <p>If set to DON'T USE, the none of the strobe alarm settings appear in the Configuration menu and the strobe circuit does not function.</p> <p>* <i>This parameter appears only if the STROBE Installation parameter in the Global Menu is set to Strobe Installed.</i></p>
Alarm-1 Level (See the Beacon 410 Detector Head Specification sheet for the detector head installed on this channel.)	The gas reading at which an alarm 1 condition occurs and the Beacon 410 activates the alarm 1 circuit for this channel.
Alarm-1 Inc/Dec (DECREASING for oxygen, INCREASING for all other channel types)	Indicates if the alarm 1 circuit is activated by gas reading INCREASING or DECREASING to the alarm 1 level.
Alarm-1 Latching (SELF-RESETTING for oxygen, LATCHING for all other channel types)	<p>If set as LATCHING, you must press the RESET button to reset the alarm 1 circuit after the alarm 1 condition passes.</p> <p>If set as SELF-RESETTING, the Beacon 410 automatically resets the alarm 1 circuit after the alarm 1 condition passes.</p>
Alarm-1 ON Delay (1 Second)	The amount of time the Beacon 410 delays activation of the alarm 1 circuit after the gas reading reaches the alarm 1 setpoint.
ALARM-1 OFF DELAY (0 Seconds)	<p>The amount of time the Beacon 410 delays resetting the alarm 1 circuit after the alarm 1 condition passes.</p> <p>* <i>This parameter appears only if the ALARM-1 Latching parameter is set to SELF-RESETTING.</i></p>

Table 7: Configuration Menu Parameters (Continued)

Channel Parameter (Factory-Set Value)	Description
ALM-1 STROBE Setting (NonResettable STROBE)	<p>If set to Resettable STROBE, the strobe can be turned off with the Reset Switch while an alarm 1 condition still exists. If set to NonResettable STROBE, the strobe cannot be turned off with the Reset Switch while an alarm 1 condition still exists.</p> <p>If set to NO STROBE, the strobe will not activate due to an alarm 1 condition.</p> <p>* <i>This parameter appears only if the STROBE Installation parameter in the Global Menu is set to Strobe Installed and the Strobe Setting parameter in the Configuration Menu is set to USE w/ Alarms Only or USE w/ Alarms and Fail.</i></p>
Alarm-2 Level (See the Beacon 410 Detector Head Specification sheet for the detector head installed on this channel.)	<p>The gas reading at which an alarm 2 condition occurs and the Beacon 410 activates the alarm 2 circuit for this channel.</p>
Alarm-2 Inc/Dec (INCREASING)	<p>Indicates if the alarm 2 condition is activated by gas readings INCREASING or DECREASING to the alarm 2 level.</p>
Alarm-2 Latching (SELF-RESETTING for oxygen, LATCHING for all other channel types)	<p>If set as LATCHING, you must press the RESET button to reset the alarm 2 circuit after the alarm 2 condition passes. If set as SELF-RESETTING, the Beacon 410 automatically resets the alarm 2 circuit after the alarm 2 condition passes.</p>
Alarm-2 ON Delay (120 Seconds for oxygen, 1 Second for all other channel types)	<p>The amount of time the Beacon 410 delays activation of the alarm 2 circuit after the gas reading reaches the alarm 2 setpoint.</p>
Alarm-2 OFF DELAY (0 Seconds)	<p>The amount of time the Beacon 410 delays resetting the alarm 2 circuit after the alarm 2 condition passes.</p> <p>* <i>This parameter appears only if the ALARM-2 Latching parameter is set to SELF-RESETTING.</i></p>
ALM-2 STROBE Setting (NonResettable STROBE)	<p>If set to Resettable STROBE, the strobe can be turned off with the Reset Switch while an alarm 2 condition still exists. If set to NonResettable STROBE, the strobe cannot be turned off with the Reset Switch while an alarm 2 condition still exists.</p> <p>If set to NO STROBE, the strobe will not activate due to an alarm 2 condition.</p> <p>* <i>This parameter appears only if the STROBE Installation parameter in the Global Menu is set to Strobe Installed and the Strobe Setting parameter in the Configuration Mode is set to USE w/ Alarms Only or USE w/ Alarms and Fail.</i></p>

Table 7: Configuration Menu Parameters (Continued)

Channel Parameter (Factory-Set Value)	Description
Alarm-3 Level (See the Beacon 410 Detector Head Specification sheet for the detector head installed on this channel.)	The gas reading at which an alarm 3 condition occurs and the Beacon 410 activates the alarm 3 circuit for this channel.
Alarm-3 Inc/Dec (DECREASING for oxygen, INCREASING for all other channel types)	Indicates if the alarm 3 circuit is activated by gas readings INCREASING or DECREASING to the alarm 3 level.
Alarm-3 Latching (SELF-RESETTING for oxygen, LATCHING for all other channel types)	If set as LATCHING , you must press the RESET button to reset the alarm 3 circuit after the alarm 3 condition passes. If set as SELF-RESETTING , the Beacon 410 automatically resets the alarm 3 circuit after the alarm 3 condition passes.
Alarm-3 ON Delay (1 Second)	The amount of time the Beacon 410 delays activation of the alarm 3 circuit after the gas reading reaches the alarm 3 setpoint.
Alarm-3 OFF DELAY (0 Seconds)	The amount of time the Beacon 410 delays resetting the alarm 3 circuit after the alarm 3 condition passes. * <i>This parameter appears only if the ALARM-3 Latching parameter is set to SELF-RESETTING.</i>
ALM-3 STROBE Setting (NonResettable STROBE)	If set to Resettable STROBE , the strobe can be turned off with the Reset Switch while an alarm 3 condition still exists. If set to NonResettable STROBE , the strobe cannot be turned off with the Reset Switch while an alarm 3 condition still exists. If set to NO STROBE , the strobe will not activate due to an alarm 3 condition. * <i>This parameter appears only if the STROBE Installation parameter in the Global Menu is set to Strobe Installed and the Strobe Setting parameter in the Configuration Mode is set to USE w/ Alarms Only or USE w/ Alarms and Fail.</i>
Relay-1 Assignment (ALARM-1)	The alarm condition that activates relay 1. It can be set for activation by the following alarm conditions: <ul style="list-style-type: none"> • ALARM-1 • ALARM-2 • ALARM-3 • ALARMS 1 or 2 • ALARMS 1 or 3 • ALARMS 2 or 3 • ALARMS 1, 2, or 3 • Use As Channel FAIL (If you choose this setting, the relay is normally energized)

Table 7: Configuration Menu Parameters (Continued)

Channel Parameter (Factory-Set Value)	Description
Relay-2 Assignment (ALARM-2)	<p>The alarm condition that activates relay 2. It can be set for activation by the following alarm conditions:</p> <ul style="list-style-type: none"> • ALARM-1 • ALARM-2 • ALARM-3 • ALARMS 1 or 2 • ALARMS 1 or 3 • ALARMS 2 or 3 • ALARMS 1, 2, or 3 • Use As Channel FAIL (If you choose this setting, the relay is normally energized)
Relay-X Assignment (ALARM-3) * <i>Relay-X will be either Relay-A for channel 1, Relay-B for channel 2, Relay-C for channel 3, or Relay-D for channel 4.</i>	<p>The alarm condition that activates relay X. It can be set for activation by the following alarm conditions:</p> <ul style="list-style-type: none"> • ALARM-1 • ALARM-2 • ALARM-3 • ALARMS 1 or 2 • ALARMS 1 or 3 • ALARMS 2 or 3 • ALARMS 1, 2, or 3 • Use As Channel FAIL (If you choose this setting, the relay is normally energized) <p>* <i>This parameter appears only if the RELAYS ABCD used as parameter in the Global Menu is set to CHANNEL ALARM RELAYS.</i></p>
NOISE FILTER (5 seconds)	<p>The noise filter feature helps “smooth out” jumpy or noisy signals from the detector head. The filter setting indicates the number of seconds over which the displayed reading is being averaged. You can set the noise filter from 1 second to 10 seconds.</p> <p>A setting of 10 seconds produces the greatest amount of smoothing, but causes the displayed gas reading to respond more slowly to changes in gas concentrations. A setting of 1 second gives the fastest gas reading response to a change in gas concentration, but gives the least amount of smoothing.</p>
Deadband (0.5% oxygen for oxygen channels; 2.0% of Full Scale in terms of the channel's units for all other channel types.)	<p>The deadband setting defines the first gas concentration that will be displayed when the gas reading increases or decreases from the normal fresh air concentration (20.9 for oxygen and 0 for all other channel types). This feature helps prevent “jumpy” readings near the normal fresh air reading.</p> <p>For example, if the zero suppression setting is 2 %LEL for a combustible channel whose range is 0 - 100% LEL, the Beacon 410 will display a reading of 0 %LEL for gas readings from -1 %LEL to 1 %LEL.</p>

Chapter 7: Input Setup Menu

Overview

This chapter describes how to use the Input Setup Menu to select each channel's detector head input type and the gas setup. The detector head input type determines whether a direct connect type or a 4 - 20 mA type of detector head will be used and the gas setup determines the target gas, detection units, and the detection range full scale. The Input Setup Menu is accessed using the ENTER control button when powering up the Beacon 410.

The Input Setup Menu includes a 5-minute timeout feature. If you do not press a button for 5 minutes, the Beacon 410 automatically returns to normal operation.

NOTE: The Beacon 410 will begin its warm-up sequence when it exits the Input Setup Menu before it enters normal operation whether because of a program timeout or because you are done with input setup and are exiting manually.

Selecting the Detector Head Input Type and Gas Setup

NOTE: The Beacon 410 must be turned off before you can enter the Input Setup Menu. If your Beacon 410 is already installed and operating, make sure that turning the Beacon 410 off will not cause unwanted alarms before continuing.

1. While the Beacon 410 is off, press and hold the ENTER button, then turn on the Beacon 410 with the ON/OFF switch.
2. Continue to press the ENTER button while the Beacon 410 turns on and the display shows **RKI Instruments Beacon 410**. Release the ENTER button when the following screen appears on the display.

```
Y o u   H a v e   E n t e r e d   T h e
      I N P U T   S E T U P   M e n u
C o n t i n u e ?   [ Y / N ]
```

3. If you want to exit the Input Menu, press and release the DOWN/NO button. The Beacon 410 will exit the Input Menu and begin the warm-up sequence.

If you want to continue in the Input Menu, press and release the UP/YES button. The Select Channel(s) screen will appear.

```
S e l e c t   C h a n n e l
                1
U P / D N   t h e n   E N T / E S C
```

- The setup that you perform will apply to all the channels that you select. Select the channel or channels you want to setup by using the UP/YES or DOWN/NO buttons to scroll through the choices and then press and release the ENTER button to accept the selection. The INPUT Type screen will appear. In the example below, channels 1 and 2 have been selected for setup.

```

CHANNEL ( S ) : 1 , 2
INPUT Type
4 - 20 mA TRANSMITTER
UP / DN then ENT / ESC

```

- Use the UP/YES or DOWN/NO button to scroll through the choices of input types. Table 8 below lists the choices of input type for the Beacon 410.

Table 8: Beacon 410 Detector Head Input Types

Detector Head Input Type	Description
4-20 mA TRANSMITTER	A 4-20 mA TRANSMITTER detector head is connected to the Beacon 410 with 2 or 3 wires, depending on the detector head model, using the AMP +, S, and - terminals on the detector/transmitter terminal strips. All calibration adjustments are made at the detector head.
PREAMP DIRECT	A PREAMP DIRECT detector head is connected to the Beacon 410 with 2 wires using the AMP + and S terminals on the detector/transmitter terminal strips. All calibration adjustments are made at the Beacon 410.
OXYGEN DIRECT (25%)	An OXYGEN DIRECT detector head is an oxygen detector head in which the oxygen detector is wired to the Beacon 410 with 2 wires using the OXY W (white) and G (green) terminals from on the detector/transmitter terminal strips. All calibration adjustments are made at the Beacon 410.
RWGB DIRECT (LEL)	An RWGB DIRECT (LEL) detector head is detector head in which the detector is wired to the Beacon 410 with 4 wires using the LEL R (red), W (white), G (green) and B (black) terminals on the detector/transmitter terminal strips. All calibration adjustments are made at the Beacon 410. This type of detector head is typically a combustible gas LEL detector head, but may be another type such as a CO ₂ detector.

- When the desired detector head input type is shown on the display, press and release the ENTER button to accept it. The PreDefined Gas Setup screen will appear.

```

CHANNEL ( S ) : 1 , 2
PreDefined Gas Setup
METHANE 100 % LEL
UP / DN then ENT / ESC

```

7. Use UP/YES or DOWN/NO button to scroll through the gas setup choices. There are several choices whose gas name, full scale, and detection units are predefined. For these choices, the gas name, full scale, and detection units are displayed. There is also one choice named **CUSTOM** that allows you to enter the gas name, full scale, and detection units.
8. When the desired setup choice is shown on the display, press and release the ENTER button to accept it.

If you selected a predefined gas setup, the Save Settings? screen will appear. Proceed to step 10.

If you selected the **CUSTOM** choice, the Gas Name screen will appear. Proceed to step 9.

NOTE: The **CUSTOM** choice is especially useful if you are connecting a 4 - 20 mA transmitter to the Beacon 410 that is not a gas detector, such as a temperature or pressure transducer.

9. If you selected the **CUSTOM** choice, perform the following steps to define the gas name, detection units, and full scale.
 - With the Gas Name screen displayed, use the UP/YES or DOWN/NO button to scroll through the gas name choices. The list includes one choice called **Spell It**. This choice allows you to enter a name that is not on the list.
 - When the desired choice is displayed, press and release the ENTER button.

If you selected a gas name, the Gas Units screen appears.

If you selected **Spell It**, a screen appears that indicates **Currently, Gas Name Is Spelled As:**. If the displayed name is OK, press and release the UP/YES button and the Gas Units screen appears
If you want to change the displayed name, perform the following steps to enter the desired gas name.
 - Press and release the DOWN/NO button. The top display line indicates **Spell Out Gas Name**.
 - An eight character wide text field appears on the left side of the third display line enclosed by single quotes. A vertical cursor appears below the far left text position indicating that this character position can be edited. Use the UP/YES or DOWN/NO button to scroll through the character choices. When the desired character is displayed, press and release the ENTER button to save that character and move to the next position. Use the ESCAPE button to return to a previous character if you want to change it.
 - Repeat the previous step until all the text positions are saved. After the last character is saved, the Units screen appears.
 - Use the UP/YES or DOWN/NO button to scroll through the units choices. When the desired units are displayed, press and release the ENTER button. The Full Scale Readout screen appears.
 - USE the UP/YES or DOWN/NO button to scroll through the available choices for the full scale setting. When the desired full scale setting is displayed, press and release the ENTER button. The Save Settings? screen appears.

10. If you want to save the setup, press and release the UP/YES button. The display will indicate that the settings have been saved before asking if you want to setup more channels.

NOTE: If you defined a custom setup by selecting the **CUSTOM** choice in the PreDefined Gas Setup screen, you will be required to review the channel parameters from the Configuration Menu. See “Viewing and Changing Channel Parameters” on page 35 for a description of the channel parameters.

If you do not want to save the setup, press and release the DOWN/NO button. You will return to the Select Channel(s) screen. Follow the instructions from step 4 above.

11. If you want to setup more channels, press and release the UP/YES button. You will return to the Select Channel(s) screen. Follow the instructions from step 4 above.

If you do not want to setup more channels, press and release the DOWN/NO button and the Beacon 410 will exit the Input Setup Menu and begin its warm-up sequence.

Chapter 8: Calibration Mode

Overview

This chapter describes how to calibrate the Beacon 410's active channels using Calibration Mode. In Calibration Mode, you can:

- Set the calibration timeout.
- Perform a fresh air adjust on selected channels.
- Perform a gas adjust on selected channels.
- View Max Spans.

Table 9 below briefly describes the four operations that can be performed in Calibration Mode. A more detailed description of each operation is given later in this chapter.

Table 9: Calibration Mode Functions

Operation	Description
SET CAL TIMEOUT	The calibration timeout sets the amount of time after the last button push while in Calibration Mode that the Beacon 410 will wait before automatically returning to normal operation.
PERFORM AIR ADJUST	This operation allows you to set the fresh air reading of the selected channel(s) to zero (20.9% for an oxygen channel).
PERFORM GAS ADJUST	This operation allows you to set the response reading of the selected channels with calibration gas.
VIEW MAX SPANS	This operation gives a measure of how much gas response adjustment remains on a direct connect type channel by allowing you to view the maximum possible adjustment on gas during the most recent calibration for each channel.

Calibration Frequency

Although there is no particular calibration frequency that is correct for all applications, a calibration frequency of every 3 to 6 months is adequate for most Beacon 410 applications. Unless experience in a particular application dictates otherwise, RKI Instruments, Inc. recommends a calibration frequency of every 3 months.

If an application is not very demanding, for example detection in a clean, temperature controlled environment where a combustible or toxic gas is not normally present, and calibration adjustments are minimal at calibration, then a calibration frequency of every 6 months may be adequate.

If an application is very demanding, for example if a combustible or toxic gas is present often and in significant concentrations or the environment is not well controlled, then more frequent calibration than every 3 months may be necessary. For combustible gas

detection using catalytic combustion type detectors, if potential catalyst poisons are known or likely to be present, more frequent calibration than every 3 months will be necessary.

Detector Head Types

The Beacon 410 can support both direct connect (internal amp) and 4-20 mA transmitter (remote amp) detector heads. Since the Beacon 410 can support both types of detector heads, there are three possible detector head combinations when calibrating the active channels:

- Direct connect detector heads only.
If all the active channels are direct connect detector heads, then all calibration adjustments are made at the Beacon 410 after calibration gas is applied to the detectors.
- 4-20 mA transmitter detector heads only.
If all the active channels are 4 - 20 mA transmitter detector heads, then all calibration adjustments are made at the detector head when calibration gas is applied to the detectors.
- Direct connect and 4-20 mA transmitter detector heads.
If both direct connect and 4-20 mA transmitter detector heads are installed, then calibration adjustments must be made at the Beacon 410 for the direct connect detector heads after applying gas to the detectors, and at the detector heads when gas is applied for the 4-20 mA transmitter detector heads.

Calibration Gas Response Memory Feature

When a direct connect detector head is installed, the Beacon 410 has the capability to “remember” the detector’s response to the calibration gas after the gas is removed from the detector during the fresh air or span (zero for an oxygen detector) adjustment procedure. This feature enables one person to perform calibration if the detector heads are mounted remotely from the Beacon 410. When zero air is applied to a detector head during a fresh air adjustment in Calibration Mode, the Beacon 410 will freeze the display reading at the lowest (highest for an oxygen detector head) response and the Beacon 410 will continue to display this reading and retain it in its memory until the fresh air adjustment procedure is completed. When calibration gas is applied to a detector head during a span (zero for an oxygen detector) adjustment in Calibration Mode, the Beacon 410 will freeze the display reading at the highest (lowest for an oxygen detector) response to the calibration gas. The calibration gas can then be removed and the Beacon 410 will continue to display this reading and retain it in its memory until the span (zero for an oxygen detector) adjustment procedure is completed.

Entering Calibration Mode

WARNING: *The Beacon 410 is not an active gas monitoring device during the calibration procedure. When you enter Calibration Mode, the 4-20 mA output signal will “freeze” at 3.5 mA for each active channel, all relays and alarm LEDs will remain in their current state at the time that you entered Calibration Mode, and the alarm buzzer and strobe will turn off if they were activated until you exit Calibration Mode. The 4 - 20 mA output signal will not indicate current readings and the relays and alarm LEDs will not resume operating normally until the Beacon 410 is in normal operation again.*

1. Assemble the calibration kit(s). See the instruction manual for each detector head for procedures specific to that detector head.
2. While in normal operation, simultaneously press and hold the ENTER and UP/YES buttons for approximately 3 seconds to enter Calibration Mode. Release the buttons when the **You Have Entered The CALIBRATION Mode...** message displays and asks if you want to continue in the Calibration Menu.
3. If you want to exit Calibration Mode, press and release the DOWN/NO button. The Beacon 410 will return to normal operation.

If you want to continue in Calibration Mode, press and release the UP/YES button to continue and display the Select Operation screen. The SET CAL TIMEOUT item will be displayed.

S	e	l	e	c	t		O	p	e	r	a	t	i	o	n									
							S	E	T		C	A	L		T	I	M	E	O	U	T			
							U	P	/	D	N		t	h	e	n		E	N	T	/	E	S	C

The next two sections describe how to set the calibration timeout and calibrate the Beacon 410's detector heads.

Calibration Timeout Setting

The calibration timeout setting defines the amount of time after the last button push that the Beacon 410 will remain in Calibration Mode before automatically exiting Calibration Mode and entering normal operation. If the Beacon 410 exits Calibration Mode because of the automatic timeout, it will begin its warm-up sequence just as it does when it is turned on.

To view or change the calibration timeout setting, do the following:

1. Navigate to the Select Operation Screen as described in the previous section.

2. With **SET CAL TIMEOUT** displayed, press and release the ENTER button. The Calibration Timeout Screen appears.

```

C a l i b r a t i o n   T i m e o u t
                1 5   m i n u t e s
U P / D N   t h e n   E N T / E S C

```

3. Use the UP/YES or DOWN/NO button to adjust the calibration timeout to the desired setting. The calibration timeout can be set from 5 minutes to 240 minutes (4 hours) in 5 minute increments. The factory set calibration timeout is 15 minutes.
4. If you want to save the displayed calibration timeout setting, press and release the ENTER button. The display will indicate that the setting has been saved before returning to the Select Operation Screen.
If you do not want to save the displayed calibration timeout setting, press and release the ESCAPE button. The display will indicate that nothing has changed before returning to the Select Operation Screen.
5. Press and release the ESCAPE button. The **You Have Entered The CALIBRATION Mode...** message displays and asks if you want to continue in Calibration Mode.
6. Press the DOWN/NO button to exit Calibration Mode and enter normal operation.

Performing a Calibration

It is possible to perform only an air adjustment or a gas response adjustment since it is not always necessary to perform a complete calibration. For example, during startup, it is typically only necessary to perform an air adjustment since the Beacon 410 is shipped with all the factory setup channels calibrated. However, for a complete calibration, you must perform both a fresh air adjustment and a gas response adjustment.

Performing a Fresh Air Adjustment

Performing a fresh air adjustment sets the gas reading in fresh air for the selected channels to zero for all channel types except oxygen. An oxygen channel is set to 20.9% in fresh air. If you suspect that the environment at a detector head location is not a fresh air environment, an environment of normal oxygen content, 20.9%, and free of combustible or toxic gasses, you will need to apply zero-emission air, also known as zero air, to the detector when making the fresh air adjustment. See the operator's manual for each detector head that you are air adjusting for instructions specific to that detector head.

To perform a fresh air adjustment for the selected channels, do the following:

1. Navigate to the Select Operation Screen as described in "Entering Calibration Mode" on page 47.
2. Use the UP/YES or DOWN/NO button to display **PERFORM AIR ADJUST** on the Select Operation Screen.
3. Press and release the ENTER button. The Select Channel(s) screen appears.

```

S e l e c t   C h a n n e l ( s )
F o r   F R E S H   A I R   A d j u s t
                1
U P / D N   t h e n   E N T / E S C

```

- Use the UP/YES or DOWN/NO button to scroll through the channel combination choices and select the channel or channels that you will air adjust.
- Press and release the ENTER button to accept the displayed choice and continue with the air adjustment. The display will alternate between the top two screens shown below. In the example below, channels 1, 2, 3, and 4 have been selected for an air adjust.

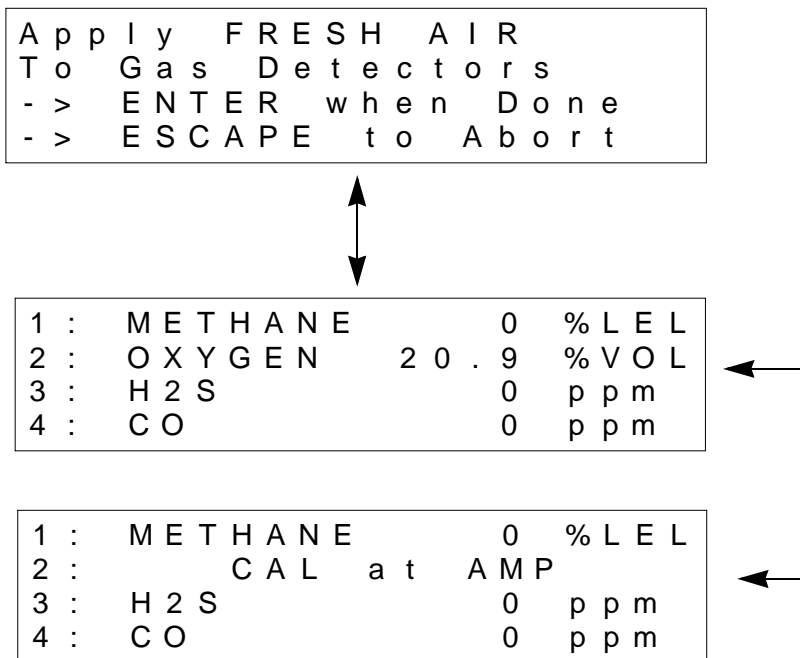

If any of the displayed channels is a 4 - 20 mA type detector head, the gas name and concentration will alternate with **CAL at AMP**. In the example above, channel 2 is a 4 - 20 mA type channel.

- Verify that the detector heads are in a fresh air environment. If you cannot confirm a fresh air environment, use a zero air cylinder to introduce fresh-air to each detector when adjusting the fresh air reading below. If you are air adjusting both 4 - 20 mA and direct connect types of detector heads, air adjust the 4 - 20 mA type detector heads at the detector heads first, then apply zero air to and air adjust the direct connect type detector heads to avoid exiting the air adjustment screens prematurely before you have adjusted the 4 - 20 mA type detector heads.
- For a 4 - 20 mA type detector head, adjust the detector head's fresh air reading (sometimes referred to as the zero reading for non-oxygen detector heads) at the detector head. See the detector head operator's manual for instructions on how to adjust the fresh air reading.
- If you are only air adjusting 4 - 20 mA type detector heads, press the ENTER button when you are done to return to the Select Operation Screen. Proceed to step 10.
If you are air adjusting both 4 - 20 mA type detector heads and direct connect detector heads, proceed to step 9.
- For direct connect type detector heads, if the detector heads are in a fresh air environment, press and release the ENTER button. The Beacon 410 will perform a fresh air adjustment and the display will indicate **AIR ADJUST PASSED** for each direct connect type detector head if the air adjust is successful. If the air adjust was

not successful for any channel, the display will indicate **AIR ADJUST FAILED** for that channel. The Beacon 410 will then return to the Select Operation screen.

If you suspect the detector area is not a fresh air environment, apply zero air to each selected detector before pressing the ENTER button to perform the fresh air adjustment. See each detector head's operator's manual for instructions to apply zero air to each detector. The Beacon 410 will freeze the display reading at the lowest level reached while applying zero air (highest level for an oxygen detector head). After applying zero air for the required amount of time, usually two minutes, remove the zero air source from the detector. Press and release the ENTER button at the Beacon 410. The Beacon 410 will perform a fresh air adjustment and the display will indicate **AIR ADJUST PASSED** for each direct connect type detector head if the air adjust is successful. The Beacon 410 will then return to the Select Operation screen.

10. If you want to perform a gas adjustment to complete the calibration, proceed to the next section, "Performing a Gas Adjustment".

If you do not want to perform a gas adjustment, press and release the ESCAPE button to return to the initial screen that says **You Have Entered CALIBRATION Mode...** and then press and release the DOWN/NO button to exit Calibration Mode and return to normal operation.

Performing a Gas Adjustment

Performing a gas adjustment sets the response level to calibration gas for the selected channels. This is also known as a span adjustment. See the operator's manual for each detector head that you are gas adjusting for instructions specific to that detector head.

To perform a gas adjustment for the selected channels, do the following:

1. Navigate to the Select Operation Screen as described in "Entering Calibration Mode" on page 47 or proceed to the next step if you just completed an air adjustment and are at the Select Operation Screen.
2. Use the UP/YES or DOWN/NO button to display **PERFORM GAS ADJUST** on the Select Operation Screen.
3. Press and release the ENTER button. The Select Channel(s) screen appears.

```
S e l e c t   C h a n n e l ( s )
F o r   C A L   G A S   A d j u s t
                1
U P / D N   t h e n   E N T / E S C
```

4. Use the UP/YES or DOWN/NO button to scroll through the channel combination choices and select the channel or channels that you will air adjust. In the gas adjustment example below, channels 1, 2, 3, and 4 have been selected.
5. Press and release the ENTER button to accept the displayed choice and continue with the gas adjustment. The display will show the calibration gas concentration that the Beacon 410 expects you to use for the gas adjustment for the first selected direct connect type channel.

```
C H A N N E L   1
C A L   G A S   T o   B e   U s e d
M E T H A N E           5 0   % L E L
U P / D N   t h e n   E N T / E S C
```

6. Use the UP/YES and DOWN;/NO buttons to make the displayed concentration match the calibration gas concentration, then press and release the ENTER button to accept it. The display will show the expected calibration gas concentration for the next selected direct connect type channel.
7. Repeat step 6 for each selected direct connect channel. When the last selected direct connect channel's calibration gas concentration has been accepted, the top two screens shown below will alternate.

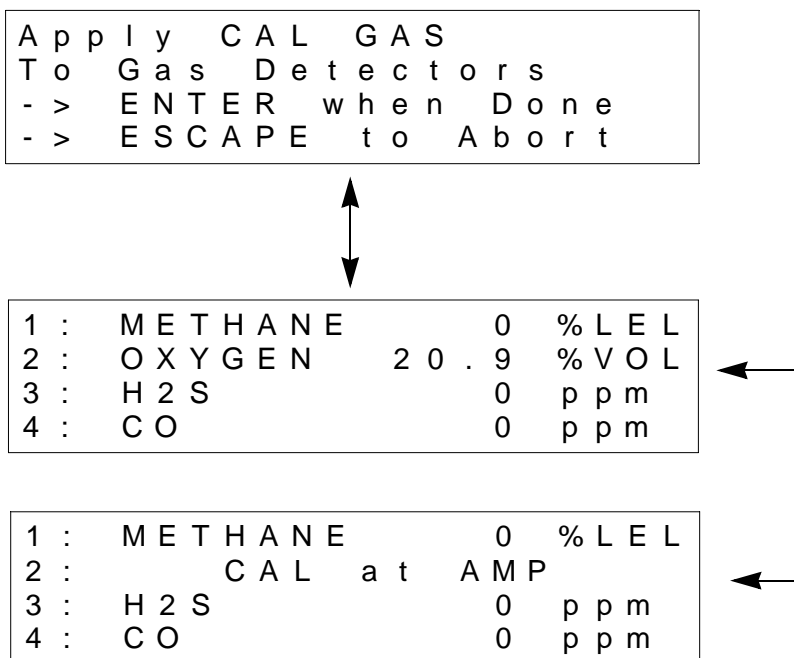

If any of the displayed channels is a 4 - 20 mA type detector head, the gas name and concentration will alternate with **CAL at AMP**. In the example above, channel 2 is a 4 - 20 mA type channel

8. For a 4 - 20 mA type detector head, adjust the detector head's gas response at the detector head. See the detector head operator's manual for instructions on how to adjust the gas response reading. This is sometimes referred to as adjusting the span (or zero for an oxygen channel).
9. If you are only gas adjusting 4 - 20 mA type detector heads, press the ENTER button when you are done to return to the Select Operation Screen. Proceed to step 12.
If you are air adjusting both 4 - 20 mA type detector heads and direct connect detector heads, proceed to step 10.
10. For direct connect type detector heads, apply calibration gas to each selected detector. See each detector head's operator's manual for instructions on how to apply gas to each detector.

When calibration gas is applied to a detector, the Beacon 410 will freeze the display gas reading at the highest level reached while the gas was applied (lowest for an oxygen detector head). After applying calibration gas for the required amount of time, usually two minutes, remove the gas from the detector. The Beacon 410 will continue to display the maximum gas response (lowest for an oxygen detector head) on the display and retain the response level in its memory.

11. After you have applied gas to each direct connect detector head, press and release the ENTER button. The Beacon 410 will perform a gas adjustment on the direct connect type channels and indicate **GAS ADJUST PASSED** for each direct connect type channel. If the air adjust was not successful for any channel, the display will indicate **AIR ADJUST FAILED** for that channel. The Beacon 410 will then return to the Select Operation screen.
12. Press and release the ESCAPE button to return to the initial Calibration Mode Screen that says **You Have Entered the CALIBRATION Menu...** and then press and release the DOWN/NO button to exit Calibration Mode and return to normal operation.

Be sure to allow enough time between the application of calibration gas and returning to normal operation for the gas reading to return to normal levels to avoid false alarms. The alarm circuits are active when the Beacon 410 returns to normal operation.

Viewing Maximum Spans

This operation allows you to see how much gas response adjustment remains on direct connect type channels after a calibration is performed. This is a useful gauge for whether or not a sensor is nearing the end of its life. When you enter the VIEW MAX SPANS screen, the Beacon 410 displays the maximum possible adjustment that the Beacon 410 could have made to the response reading with the calibration gas that was used for each direct connect type channel during the most recent successful calibration. So if a 0 - 100 %LEL channel is calibrated using 50 %LEL gas and the maximum indicated span in the VIEW MAX SPANS screen is 95 %LEL, this means that there was enough adjustment left on that channel to set the reading to 95 %LEL when the detector was exposed to 50 %LEL gas. If the maximum span value is close to the calibration gas value, for example if it is 53 %LEL for a 0 - 100 %LEL channel when 50 %LEL calibration gas is used, the sensor should be replaced soon.

To make the maximum span values as meaningful as possible, there is a limit to how much remaining adjustment the screen will indicate. The maximum remaining adjustment that will be shown for any channel is 3 times the calibration gas concentration even if the Beacon 410 could have adjusted it higher. For example, if 50% LEL gas was used to calibrate a 0 - 100 % LEL channel, the highest maximum span value that will be displayed is 150 %LEL. If the maximum span adjustment possible for a channel is more than 3 times the calibration gas value, a "+" sign will be displayed next to the maximum span value.

The maximum span values that are displayed are from the most recent successful calibration for each channel. So they are most useful soon after a calibration is performed. If an extended period of time, for example 2 or 3 months, has passed since the last successful calibration on a particular channel, the maximum span value for that channel may no longer be accurate.

The maximum span value only has meaning for direct connect type channels. For 4 - 20 mA transmitter type channels, instead of a maximum span value, **4 - 20 mA Xmtr** will be displayed for those channels.

To view the maximum span values, do the following:

1. Navigate to the Select Operation Screen as described in "Entering Calibration Mode" on page 47 or navigate to the Select Operation Screen after performing a calibration.
2. Use the UP/YES or DOWN/NO button to display **VIEW MAX SPANS** on the Select Operation Screen.

3. Press and hold the ENTER button to display the maximum spans. In the example below, channels 1, 2, and 3 are active and channel 2 is a 4 - 20 mA type channel.

1	:	M E T H A N E	1 5 0 + % L E L
2	:	4 - 2 0 m A	X m t r
3	:	O X Y G E N	3 7 . 5 % : V O L

4. Release the ENTER button to return to the Select Operation screen.
5. Press and release the ESCAPE button to return to the initial Calibration Mode Screen that says **You Have Entered the CALIBRATION Menu...** and then press and release the DOWN/NO button to exit Calibration Mode and return to normal operation.

Chapter 9: RS-485 Modbus Output

Overview

This chapter describes the Beacon 410's RS-485 Modbus output and how to configure the Beacon 410 to make use of it. It also discusses how to wire the Beacon 410 into a Modbus system.

The Beacon 410 provides an RS-485 serial communications interface. It is a Modbus Slave Device, supporting 2-wire RS-485 Modbus RTU serial communications.

Wiring the Beacon 410 in a Modbus System

The Beacon 410 is a 2-wire Modbus RTU device. When wiring the Beacon 410 into a Modbus system, adhere to standard Modbus wiring practices per the Modbus Over Serial Line Specification and Implementation Guide V1.0 or later. This document can be found online at www.modbus.org/specs.php.

The Modbus protocol supports a maximum of 247 unique slave addresses (1-247). The Beacon 410's line driver provides for up to 32 Beacon 410s (or some combination of Beacon 410s and other Modbus slave devices such as the RKI Instruments M2) to be connected together without the need for a repeater. Figure 15 & Figure 16 below illustrate typical Beacon 410 wiring configurations. If more than 32 Beacon 410s (or Beacon 410s and other slave devices) need to be connected together, an RS-485 repeater(s) should be used such that no more than 32 Beacon 410s reside on any given network segment.

The MODBUS terminals are located on the controller terminal strip (See Figure 1). The following signals are available at the Modbus terminals:

Table 10: Modbus Terminal Signals

Modbus Terminal Label (RS-485 Name)	Modbus Signal Name
A	D0
B	D1
C	Common

Recommended Modbus Wiring

The recommended Modbus wiring for the Beacon 410 is illustrated in Figure 14 below.

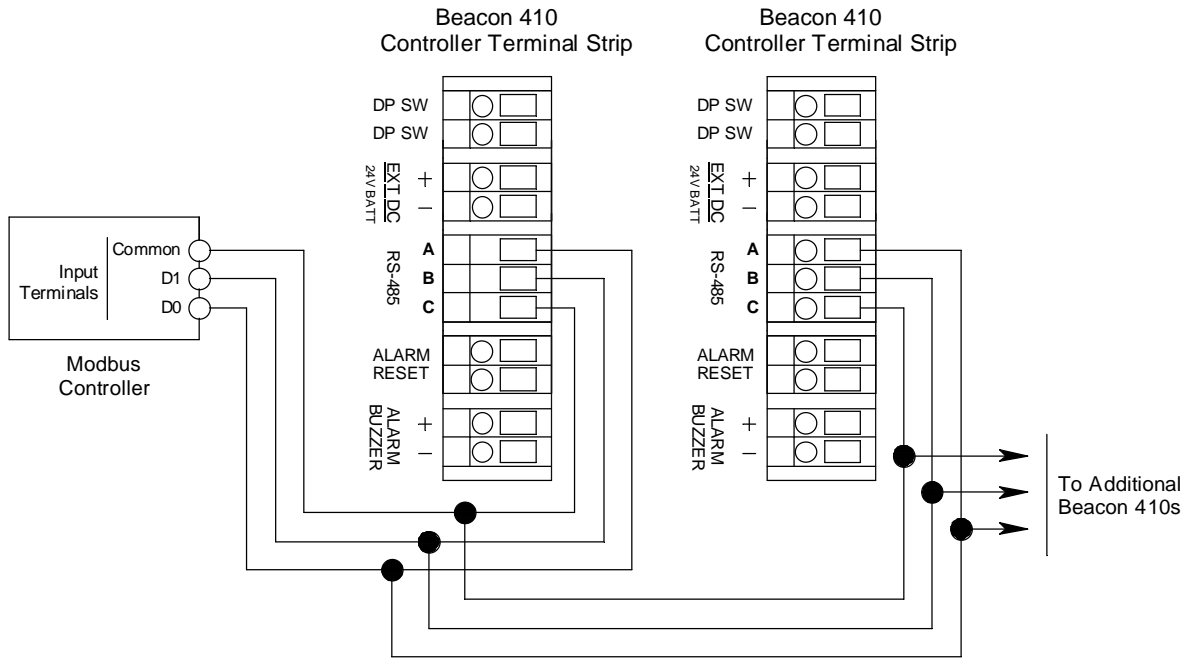

Figure 14: Recommended Modbus Wiring

Termination Jumper

The Beacon 410 includes a 2-pin termination header (see Figure 1) that may need to be installed when the Beacon 410 is used in a Modbus system. Every Beacon 410 is supplied with a termination jumper (a jumper block) installed onto this header. If the Beacon 410 is not used in a Modbus system, this jumper has no function. When the Beacon 410 is installed in a Modbus system, this jumper must be installed in a Beacon 410 that is at the end of a Modbus line. Any Beacon 410 in a Modbus system that is not at the end of a line must have the termination jumper removed (see Figure 15 & Figure 16 below).

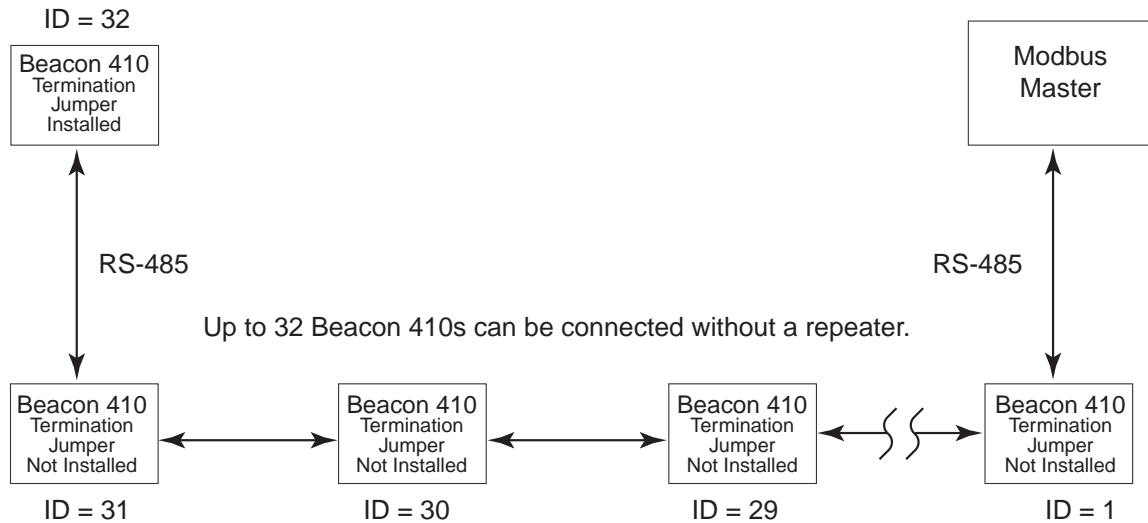
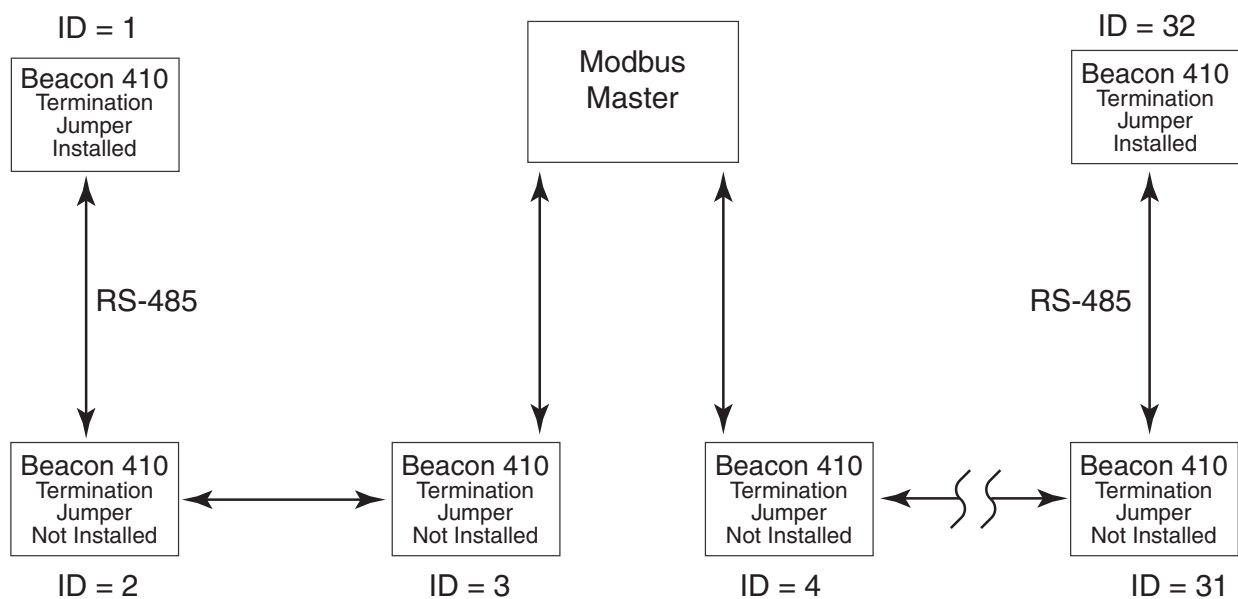

Figure 15: Multiple Beacon 410s in a Daisy Chain Configuration



Up to 32 Beacon 410s can be connected without a repeater.

Figure 16: Multiple Beacon 410s in a Two Branch Configuration

Using the Beacon 410 in a 4-wire Modbus System

Although the Beacon 410 is a 2-wire Modbus RTU device, it can be used with a 4-wire Modbus controller if the system wiring is modified as follows:

- Connect the controller's TxD0 and RxD0 wires together and use this connection as the 2-wire Modbus D0 signal.
- Connect the controller's TxD1 and RxD1 wires together and use this connection as the 2-wire Modbus D1 signal.
- Connect these D0 and D1 signals and the common wire from the controller to the 2-wire Modbus Network of Beacon 410s.

Modbus Menu

The Modbus Menu allows you to configure various parameters relating to the Modbus setup of the Beacon 410. The Modbus Menu includes a 5-minute timeout feature. If you do not press a control button for 5 minutes, the Beacon 410 automatically returns to normal operation.

NOTE: If the Beacon 410 returns to normal operation because of a timeout, it enters a warm-up period just as it does when it is first turned on.

1. While in normal operation, simultaneously press and hold the ENTER and DOWN/NO buttons for approximately 5 seconds to enter the Modbus Menu. Release the buttons when the **You Have Entered the MODBUS Menu** message appears on the display.

2. Press and release the UP/YES button to continue in the Modbus Menu to the Modbus Feature Enable/Disable screen.

```

MODBUS Feature is :
                D I S A B L E D
UP / DN  t h e n  E N T / E S C

```

3. In the parameter screens, use the ENTER button to accept a displayed parameter setting and proceed to the next parameter or the ESCAPE button to backup a screen.
4. If you want to change a displayed parameter setting, use the UP/YES or DOWN/NO button to change the parameter to the desired setting, then press and release the ENTER button to accept the change and proceed to the next screen.
5. Continue through the parameter setting screens changing any parameter settings as needed until the following message appears on the display.

```

S a v e  S e t t i n g s ?
[ Y / N ]
[ E S C A P E ]  t o  b a c k  u p

```

6. To save the channel parameter settings, press and release the UP /YES button. The screen will indicate that the Beacon 410 is saving the settings for a few seconds then the Beacon 410 will return to normal operation.

If you do not want to save the channel parameter settings, press and release the DOWN/NO button. The display will indicate that no settings have been changed for a few seconds then the Beacon 410 will return to normal operation.

Table 11 below lists the Modbus configuration parameters that can be configured in the Modbus Menu along with the factory set value for each parameter.

Table 11: Modbus Configuration Parameters

Modbus Mode Parameter	Available Settings & Description
Enabled/Disabled	Can be set to ENABLED or DISABLED (factory setting). Enables or disables the Modbus output.
Slave ID	The Slave ID can be set to values from 1 (factory setting) to 247. The Beacon 410 will only receive messages from the Master which are addressed to this Slave ID (except for broadcast messages which are received by all slaves)
Baud Rate	Can be set to 1200, 2400, 4800, 9600 (factory setting), 14440, & 19200
Parity	EVEN (factory setting), ODD, NONE

Table 11: Modbus Configuration Parameters (Continued)

Modbus Mode Parameter	Available Settings & Description
Response Delay	<p>The response delay can be set from 0 (factory setting) to 20 mS.</p> <p>This is an optional additional delay inserted by the Beacon 410 prior to returning a response message to the Master. It may be helpful in some installations where the Master's preparedness to receive responses might be delayed.</p>

NOTE: All Beacon 410s on a Modbus network must be configured with the same baud rate and parity, and each Beacon 410 must have a unique slave ID. For a Beacon 410 to participate on a network, the ENABLED/DISABLED setting must be set to ENABLED.

Supported Modbus Functions

The Beacon 410 supports Function Code 03, Read Holding Registers. There are a total of 57 registers available to be read via this Function Code.

Register 40001, Instrument Information

The format for the first register, register 40001, is shown below in Table 12. Register 40001 gives information about the instrument as a whole, and should be checked before reading or interpreting the channel data in the registers that follow. When the Beacon 410 is in any operating menu or mode other than normal operation, the channel registers simply hold their existing values. Once the Beacon 410 returns to normal operation, the channel registers are updated each second..

Table 12: Register 40001

Current Operating Mode (MS-Byte)	Common Resource Status Bits "1" = Energized "0" = De-Energized (LS-Byte)
<ul style="list-style-type: none"> • 0 = Normal Operation • 1 = Factory (Reserved) • 2 = Input Setup Menu • 3 = Channel Configuration Menu • 4 = Global Menu • 5 = Modbus Menu • 6 = Calibration Mode • 7 = Min/Max Display • 8 = Low Power Standby 	<ul style="list-style-type: none"> • Bit-7 (msb) = Common Fail Relay • Bit-6 = Relay-A • Bit-5 = Relay-B • Bit-4 = Relay-C • Bit-3 = Relay-D • Bit-2 = Strobe (optional) • Bit-1 = Audible Alarm (Buzzer) • Bit-0 (lsb) = (this bit is not used)

Registers 40002 - 40015, Channel 1 Information

Register 40002

Table 13 below shows the information in register 40002.

Table 13: Register 40002

Channel Operational State (MS-Byte)	Channel Status Bits (LS-Byte)
<ul style="list-style-type: none"> • 0 = (this code is not used) • 1 = Standby • 2 = Normal Operation • 3 = Warm Up • 4 = Fail • 5 = Post-Calibration • 6 = Low Power 	<ul style="list-style-type: none"> • Bit-7 (msb) = Relay-1 (1 = energized) • Bit-6 = Relay-2 (1 = energized) • Bit-5 = (this bit is not used) • Bit-4 = Alarm-1 (1 = asserted) • Bit-3 = Alarm-2 (1 = asserted) • Bit-2 = Alarm-3 (1 = asserted) • Bits[1:0] = Channel Usage Code <ul style="list-style-type: none"> [00] = Not Used [01] = Standby [10] = Active [11] = unused code

Registers 40003 & 40004

The 32 bits in registers 40003 and 40004 contain the channel 1 numerical reading in single precision floating point IEEE format.

Register 40005

The 16 bits in register 40005 contain the channel 1 numerical reading in integer form omitting the sign (+ or -) and the decimal point.

Register 40006

Table 14 below shows the information in register 40006.

Table 14: Register 40006

Channel Reading Sign (+/-) (MS-Byte)	Channel Decimal Point Position (LS-Byte)
<ul style="list-style-type: none"> • 0 = Positive (+) • 1 = Negative (-) 	<ul style="list-style-type: none"> • 0 = No Decimal Point • 1 = .x • 2 = .xx • 3 = .xxx

Registers 40007 - 40010

The 8 bytes (characters) in these registers contain the channel gas name in ASCII characters.

Registers 40011 - 40013

The 6 bytes (characters) in these registers contain the channel gas reading in ASCII characters.

Registers 40014 - 40015

The 4 bytes (characters) in registers 40014 and 40015 contain the channel gas units in

ASCII characters.

Registers 40016 - 40029, Channel 2 Information

Register 40016

Table 15 below shows the information in register 40016.

Table 15: Register 40016

Channel Operational State (MS-Byte)	Channel Status Bits (LS-Byte)
<ul style="list-style-type: none"> 0 = (this code is not used) 1 = Standby 2 = Normal Operation 3 = Warm Up 4 = Fail 5 = Post-Calibration 6 = Low Power 	<ul style="list-style-type: none"> Bit-7 (msb) = Relay-1 (1 = energized) Bit-6 = Relay-2 (1 = energized) Bit-5 = (this bit is not used) Bit-4 = Alarm-1 (1 = asserted) Bit-3 = Alarm-2 (1 = asserted) Bit-2 = Alarm-3 (1 = asserted) Bits[1:0] = Channel Usage Code [00] = Not Used [01] = Standby [10] = Active [11] = unused code

Registers 40017 & 40018

The 32 bits in registers 40017 and 40018 contain the channel 2 numerical reading in single precision floating point IEEE format.

Register 40019

The 16 bits in register 40019 contain the channel 2 numerical reading in integer form omitting the sign (+ or -) and the decimal point.

Register 40020

Table 16 below shows the information in register 40020.

Table 16: Register 40020

Channel Reading Sign (+/-) (MS-Byte)	Channel Decimal Point Position (LS-Byte)
<ul style="list-style-type: none"> 0 = Positive (+) 1 = Negative (-) 	<ul style="list-style-type: none"> 0 = No Decimal Point 1 = .x 2 = .xx 3 = .xxx

Registers 40021 - 40024

The 8 bytes (characters) in these registers contain the channel gas name in ASCII characters.

Registers 40025 - 40027

The 6 bytes (characters) in these registers contain the channel gas reading in ASCII characters.

Registers 40028 - 40029

The 4 bytes (characters) in registers 40028 and 40029 represent the channel gas units in ASCII characters.

Registers 40030 - 40043, Channel 3 Information

Register 40030

Table 17 below shows the information in register 40030.

Table 17: Register 40030

Channel Operational State (MS-Byte)	Channel Status Bits (LS-Byte)
<ul style="list-style-type: none">• 0 = (this code is not used)• 1 = Standby• 2 = Normal Operation• 3 = Warm Up• 4 = Fail• 5 = Post-Calibration• 6 = Low Power	<ul style="list-style-type: none">• Bit-7 (msb) = Relay-1 (1 = energized)• Bit-6 = Relay-2 (1 = energized)• Bit-5 = (this bit is not used)• Bit-4 = Alarm-1 (1 = asserted)• Bit-3 = Alarm-2 (1 = asserted)• Bit-2 = Alarm-3 (1 = asserted)• Bits[1:0] = Channel Usage Code<ul style="list-style-type: none">[00] = Not Used[01] = Standby[10] = Active[11] = unused code

Registers 40031 & 40032

The 32 bits in registers 40031 and 40032 contain the channel 2 numerical reading in single precision floating point IEEE format.

Register 40033

The 16 bits in register 40033 contain the channel 2 numerical reading in integer form omitting the sign (+ or -) and the decimal point.

Register 40034

Table 18 below shows the information in register 40034.

Table 18: Register 40034

Channel Reading Sign (+/-) (MS-Byte)	Channel Decimal Point Position (LS-Byte)
<ul style="list-style-type: none">• 0 = Positive (+)• 1 = Negative (-)	<ul style="list-style-type: none">• 0 = No Decimal Point• 1 = .x• 2 = .xx• 3 = .xxx

Registers 40035 - 40038

The 8 bytes (characters) in these registers contain the channel gas name in ASCII characters.

Registers 40039 - 40041

The 6 bytes (characters) in these registers contain the channel gas reading in ASCII

characters.

Registers 40042 - 40043

The 4 bytes (characters) in registers 40042 and 40043 contain the channel gas units in ASCII characters.

Registers 40044 - 40057, Channel 4 Information

Register 40044

Table 19 below shows the information in register 40044.

Table 19: Register 40044

Channel Operational State (MS-Byte)	Channel Status Bits (LS-Byte)
<ul style="list-style-type: none"> • 0 = (this code is not used) • 1 = Standby • 2 = Normal Operation • 3 = Warm Up • 4 = Fail • 5 = Post-Calibration • 6 = Low Power 	<ul style="list-style-type: none"> • Bit-7 (msb) = Relay-1 (1 = energized) • Bit-6 = Relay-2 (1 = energized) • Bit-5 = (this bit is not used) • Bit-4 = Alarm-1 (1 = asserted) • Bit-3 = Alarm-2 (1 = asserted) • Bit-2 = Alarm-3 (1 = asserted) • Bits[1:0] = Channel Usage Code <ul style="list-style-type: none"> [00] = Not Used [01] = Standby [10] = Active [11] = unused code

Registers 40045 & 40046

The 32 bits in registers 40045 and 40046 contain the channel 2 numerical reading in single precision floating point IEEE format.

Register 40047

The 16 bits in register 40047 contain the channel 2 numerical reading in integer form omitting the sign (+ or -) and the decimal point.

Register 40048

Table 20 below shows the information in register 40048.

Table 20: Register 40048

Channel Reading Sign (+/-) (MS-Byte)	Channel Decimal Point Position (LS-Byte)
<ul style="list-style-type: none"> • 0 = Positive (+) • 1 = Negative (-) 	<ul style="list-style-type: none"> • 0 = No Decimal Point • 1 = .x • 2 = .xx • 3 = .xxx

Registers 40049 - 40052

The 8 bytes (characters) in these registers contain the channel gas name in ASCII characters.

Registers 40053 - 40055

The 6 bytes (characters) in these registers contain the channel gas reading in ASCII characters.

Registers 40056 - 40057

The 4 bytes (characters) in registers 40056 and 40057 contain the channel gas units in ASCII characters.

Chapter 10: Maintenance

Overview

This chapter describes preventive maintenance procedures for the Beacon 410 and how to replace the AC fuses. It includes a troubleshooting guide for problems you may encounter with the Beacon 410.

Preventive Maintenance

Preventive maintenance of the Beacon 410 consists of daily, monthly, and quarterly procedures to ensure that the installed detector heads remain on zero (20.9 for oxygen) in fresh air and are responsive to the target gas. See the detector head operator's manuals for preventive maintenance procedures for each installed detector head.

Troubleshooting

Table 21 describes symptoms, probable causes, and recommended actions for the most common problems you may encounter with the Beacon 410.

NOTE: This troubleshooting guide describes **Beacon 410** problems only. See the detector head operator's manuals for preventive maintenance procedures that apply to the detector heads installed on your Beacon 410.

Table 21: Troubleshooting the Beacon 410

Condition	Symptom(s)	Probable Causes	Recommended Action
No Power to Instrument and/or Display PCB	<ul style="list-style-type: none">The PILOT light is off.The display screen is blank.	<ul style="list-style-type: none">The power wiring is disconnected or misconnected.The AC fuse is blown.The display cable is disconnected or misconnected.	<ol style="list-style-type: none">Verify that the wiring to the power source is correct and secure.At the Beacon 410, verify that the wiring to the AC in terminal strip is correct and secure.Check the continuity of the AC fuses.Verify that the display cable is connected. The display (ribbon) cable plugs into a rectangular connector on the top edge of the control PCB and on the top edge of the main PCB (labeled Front Panel).If the power difficulties continue, contact RKI for further instruction.

Table 21: Troubleshooting the Beacon 410 (Continued)

Condition	Symptom(s)	Probable Causes	Recommended Action
Frequent or Suspect Alarms	<ul style="list-style-type: none"> • The Beacon 410 alerts you to frequent or suspect alarms. • The detector heads' fresh air readings remain on zero (20.9 for oxygen) despite alarm occurrences. 	<ul style="list-style-type: none"> • The Beacon 410 is experiencing false readings due to RFI or EMI. • The detector head wiring has one or more intermittent connections. 	<ol style="list-style-type: none"> 1. Verify that the detector head wiring is properly shielded. 2. Verify that the detector head wiring is correct and secure. 3. Verify that power and detector head wiring is routed through separate conduit hubs on the bottom of the Beacon 410 housing. 4. Increase the alarm on delay setting in the Configuration Menu. 5. Increase the noise filter in the Configuration Menu. 6. If the frequent or suspect alarm difficulties continue, contact RKI for further instruction.
Momentarily Unstable Gas Readings on Display	<ul style="list-style-type: none"> • The display reading for one or more channels rises or falls briefly and then returns to the normal fresh air reading. 	<ul style="list-style-type: none"> • The Beacon 410 is experiencing false readings due to RFI or EMI. • The detector head wiring has one or more intermittent connections. • The noise filter setting is too low. • The dead band setting is too low. • The display screen is malfunctioning. 	<ol style="list-style-type: none"> 1. Verify that the detector head wiring is properly shielded. 2. Verify that the detector head wiring is correct and secure. 3. Verify that power and detector head wiring is routed through separate conduit hubs on the bottom of the Beacon 410 housing. 4. Increase the noise filter setting in the Configuration Menu. 5. Increase the dead band setting in the Configuration Menu. 6. If the difficulties continue, contact RKI for further instruction.
Buzzer not Working	<ul style="list-style-type: none"> • The buzzer does not sound an audible alarm during alarm conditions. • The buzzer sounds weak or broken. 	<ul style="list-style-type: none"> • The buzzer is disconnected or misconnected. • The buzzer is malfunctioning. 	<ol style="list-style-type: none"> 1. Verify that the wiring to the ALARM BUZZER - and ALARM BUZZER + terminals of the controller terminal strip is correct and secure. 2. If the buzzer difficulties continue, contact RKI for further instruction.
Reset Switch not Working	<ul style="list-style-type: none"> • Depending on the instrument setup, the buzzer or strobe does not turn off in the appropriate situation when the reset switch is pressed. • The applicable alarm circuit does not reset when you press the reset switch after an alarm condition passes. 	<ul style="list-style-type: none"> • The reset switch is disconnected or misconnected. • The reset switch is malfunctioning. • The Beacon 410 is not properly setup for the desired reset switch operation. 	<ol style="list-style-type: none"> 1. Verify that the wiring to the ALARM RESET (2) terminals of the controller terminal strip is correct and secure. 2. If the reset switch difficulties continue, contact RKI for further instruction. 3. Make sure that the Beacon 410 is properly setup in the Global Menu and Configuration Menus for the desired reset switch operation.

Replacing the AC Fuses

The Beacon 410 has two user serviceable AC fuses.

NOTE: To replace other components of the Beacon 410, contact RKI Instruments, Inc., for further information.

1. Turn off or unplug all incoming power to the Beacon 410.
2. Open the Beacon 410 housing door, then place the power switch in the OFF position.
3. The fuses are located to the left of the AC in terminal strip. Use a flat-blade screwdriver to rotate the applicable fuse holder 1/4 turn counterclockwise. The fuse holder releases from the socket.
4. Remove the fuse holder from the socket, then remove the fuse from the fuse holder.

CAUTION: *Verify that the replacement fuses are the same type and rating as the fuses you are replacing. The Beacon 410's fuses are fast blow fuses rated for 6A, 250 V*

5. Install the replacement fuse in the fuse holder, then place the fuse holder in the socket.
6. Push the fuse holder into the socket, then turn the holder 1/4 turn clockwise to secure it in the socket.
7. Plug in or turn on all incoming power to the Beacon 410.
8. Place the Beacon 410's power switch in the ON position, then verify that the PILOT light is on.
9. Close and secure the housing door.

Parts List

Table 22 lists the part numbers and descriptions for replacement parts and accessories offered for the Beacon 410 Gas Monitor.

Table 22: Parts List, Beacon 410 Gas Monitor

Part No.	Description
18-0107RK	Conduit Hub (3/4 in.)
43-0440RK	Reset Switch
43-4170RK	Fast Blow Fuse, 6A, 250 V
51-0096RK	Strobe/horn, 10-33 VDC, NEMA 4X
52-1016RK	Buzzer
71-0131RK	Beacon 410 Gas Monitor Operator's Manual (this document)